

## Models of Elements for EMI filters

**Abstract.** This paper deals with the modeling of the EMC filter in wide frequency range. The filter model is created from the models of the EMI filter components. At higher frequencies spurious elements of the components have large influence, which is necessary to describe in the models. EMI filter is composed of the LC low pass structures. Spurious elements of the individual components have a significant effect on the attenuation characteristics.

**Streszczenie.** Przedstawiono metody projektowania filtru EMI dla szerokiego zakresu częstotliwości. Punktem wyjścia są modele komponentów filtru. Przy wysokich częstotliwościach ważną rolę odgrywa uwzględnienie wpływów zjawisk pasożytniczych. (Modelowanie elementów filtrów EMI)

**Keywords:** Electromagnetic compatibility EMC, EMI filters, insertion loss, model resistance, model capacitor, model mutual inductance.

**Słowa kluczowe:** kompatybilność elektromagnetyczna, filtry EMI, modelowanie.

### Introduction

An EMI filter is a low pass filter, usually design as a LC circuit. This type of EMI filter is often used in the EMC, nowadays. The main parameter of the EMI filters is attenuation characteristic. This curve is strongly influenced by the frequency range and impedance conditions at the input and output terminals of filter. It is necessary to distinguish between measurement systems, in which the EMI filter produces different insertion loss characteristics.

EMI filter is a linear two-gate circuit connected between the source of interference and a receiver of the noise. The Fig.1 shows the position of the EMI filter in the supply network.

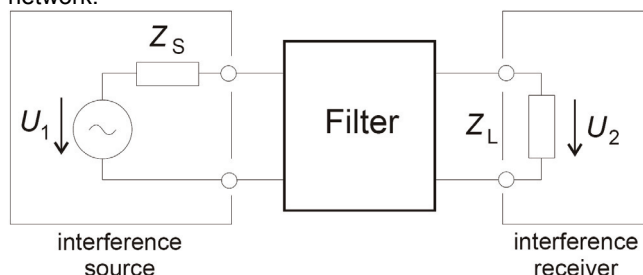

Fig.1 The EMI filter as a ideal two-gate circuit.

Insertion loss of the EMI filter is determined by a basic equation 1, which is possible describe over various parameters such as four-pole cascade parameters (complex) impedance parameters or S-parameters.

$$(1) \quad L = 20 \cdot \log \frac{U_{20}}{U_2} .$$

The  $U_2$  is voltage at the output of the EMI filter on the loading impedance, the  $U_{20}$  is the same voltage, but the filter has been unplugged.

Impedance conditions on input or on output of the EMI filter can not be accurately determined. At input EMI filter is the uncertain impedance given with parameters of power supply, which are frequency dependent and variable according to type of power supply network. The output of EMI filter is affected by the load impedance, which is usually unknown and time variable. Impedance conditions used for measurement insertion loss characteristics are standardized by the International Standard CISPR 17 [1]. Under this standard, we can distinguish several measurement methods due to different impedance conditions at input and output terminals of EMI filter. Standard measurement method considered on input and output terminals impedance with value 50  $\Omega$ .

Approximate methods for EMI filters considered the input impedance 0.1  $\Omega$  and 100  $\Omega$  output impedance, and vice versa. However, impedance conditions in most cases do not correspond to reality.

The ideal solution is creating measurement systems contained all possible impedance conditions which are expected on the input or output EMI filter. This idea leads to the creation of a universal model of the filter. EMI filter model respects the influence of spurious elements and can simulate the behavior of the filter in wide frequency range. In this paper, is considered the most commonly used impedance system 50  $\Omega$ / 50  $\Omega$ .

Terminal arrangement of EMI filter for measurements depends on type of interference. The standard defines three types of possible interference (symmetrical, asymmetrical, non symmetrical). It is therefore particularly important to distinguish between asymmetrical or symmetrical insertion losses of EMI filter. These basic configurations are considered in this paper to create the universal EMI filter model.

### Model of EMI filter

EMI filter is composed of mutual inductance, capacitor  $C_x$  or  $C_y$ . Some EMI filters contains resistor. All components are possible to describe by a model which respects their behavior at high frequencies. Spurious elements of individual components have an impact on the EMI filter insertion loss.

Capacitor is a component used to store electrical charges. The basic property is the capacity that, however, with increasing frequency is influenced by the spurious elements. At higher frequencies is starting to show significant series inductance represents the parasitic inductance. The size is due mainly to the internal arrangement of connections. Impedance increases with frequency and there is a series resonant circuit. Above the resonant frequency behave as an inductance. Another element of the parasitic capacitor is the leakage resistance.

The replacement scheme that respects the real properties of the capacitor is shown in fig. 2 [3]. The capacitor model is used in connection EMI filter model.



Fig. 2 Capacitor model.

Capacitor  $C_x$  is designed for use in environment where the dielectric breakdown can not endanger the safety of human life. Capacitor  $C_y$  connection between the phase and guard wire and grounded instrument housing. For the

design of EMI filters is therefore necessary to consider spurious elements of the capacitors. It is necessary to choose capacitors with minimum parasitic inductance and minimal serial loss resistance.

Inductor consists of wire wound on the core. There are several types of inductors. The EMC chokes are frequently used. Similar to capacitor choke change with increasing frequency the character of their behavior. At certain frequency spurious elements of inductor begin to dominate. The most problematic spurious element for inductor is a parasitic capacity of the windings. Impedance a coil does not grow linearly, over a certain resonance frequency coil begins to behave like a capacitor and the effect of suppression significantly worsens. It is necessary to consider winding resistance loss. The replacement scheme of inductor is shown in fig. 3 [2]. The inductor model is used in the EMI filter model.

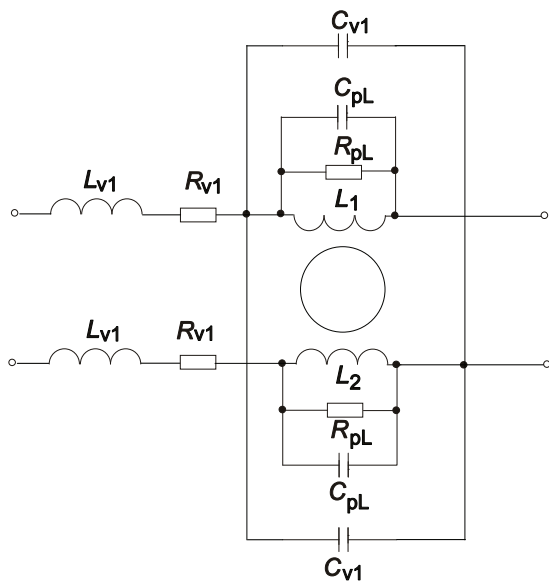

Fig. 3 Model of mutual inductance

The ideal resistor has only one parameter that is independent on external influences. Real resistor is made of a material having real electrical resistance. In addition to the real resistance have a serial inductance and a parallel capacity. Model of Resistor is shown in Fig 4. The parasitic values are noticeably manifested at higher frequencies passing current. The model is used for EMI filters, which involves resistor in their structure.

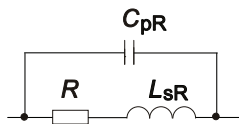

Fig. 4 Resistor model.

EMI filter model is composed of these models, which describe the behavior of real components. Unknown elements of the model are the spurious elements of individual components. The optimization routine was done in an optimization tool Ansoft Designer. Levenberg Marquardt optimization was used for obtaining values of parasitic elements for proposed models of EMI filters. This algorithm belongs to the gradient methods. Gradient method uses the gradient estimation to determine numerical calculation. Gradient means direction of the growth. In math indicates differential operator, whose result is a vector field

indicating the direction and size of the largest changes in the scalar field. Levenberg Marquardt based on the Newton nonlinear least-squares. The optimal parameters are determined by minimizing the quadratic function [6]:

$$(2) \quad \min \sum_i f_i(x) = \sum_i (y_i - f_i(x))^2.$$

Hess matrix  $H(f)$  is used for searching extremes. The disadvantage of Newton method is that  $H(f)$  does not have to always be positively definite. The minimum function does not have to be found. Levenberg Marquardt algorithm eliminates this problem by setting area around the examined point (Trust region). The essential modification is the determination of the gradient function. Functional values are calculated vectors of partial derivatives (gradient). Arrangement matrix created Jacobi matrix (3). The combination of both techniques caused decision between two extremes. One is designed using Newton method and second with slope gradient [6].

$$(3) \quad J(f) = \begin{pmatrix} \frac{\partial f_1}{\partial x_1} & \frac{\partial f_1}{\partial x_n} \\ \frac{\partial f_n}{\partial x_1} & \frac{\partial f_n}{\partial x_n} \end{pmatrix}$$

Levenberg Marquardt used the iterative method of calculation. It is necessary to establish initial estimate values before first calculation. After each step of the calculation, estimate is replaced by more precise result. All process is repeated until finding minimum error function in Ansoft designer (Function Cost) is not minimized. This method has the disadvantage in lower precision of the results. The advantage is a good convergence and robustness in the optimization data [6].

The calculation is considered as unknown elements the parasitic characteristics of individual components. But the parts that actually contain the EMI filter must be taken with a certain tolerance. Tolerance was set to  $\pm 10\%$  for optimization. It is necessary to distinguish the arrangement input terminals of the EMI filter. The calculation was performed for the asymmetric and the symmetric interference signals. The models for the calculations are slightly different. Parameters  $R_{v1}$ ,  $L_{v1}$ , and  $C_{v1}$  were not determined for asymmetric interference. Neither of the parameters did not have significant influence on the course of transmission characteristics of the EMI filter. For symmetric interference was used a complete model. 30 key frequencies from 0 Hz up to 100 MHz were chosen for basic calculation. These points were the reference course of optimization. In ideal situation should occur zero tolerance. In fact, the tolerance is greater. It can be seen in Fig. 6, 8, 10, 12. Deviations arise from several reasons. One reason is the inaccuracy of models. At higher frequencies has an effect on final transfer of the EMI filter as well as other aspects of parasitic characteristics specific components EMI filter. Other factors include arrangement of components on the PCB. There is also various components interaction. The interaction may have even greater impact than spurious elements of components [4]. PCB has greater impact on the transmission of EMI filter with increasing frequency. Other influences include measurement error, which consists of several parts. It is very important in these process option key frequencies from the measured data. From these values, the optimization tool tries to find the ideal solution. But the results are strongly affected by the robustness optimization. The resulting values are then simulated in Ansoft Designer and final waveform is compared with measured data.

For presentation of results have been selected four commercially used EMI filters. Each filter is shown in the basic schematic connection without considering presented models the individual components. Connection measuring terminal differ according to the investigated component interference. All the EMI filters were measured and simulated in impedance system  $50 \Omega / 50 \Omega$ . This impedance system is often used, but can not be described as the possible worst-case. All measurements and simulations were performed in the frequency range from 0 Hz to 100 MHz. The circuitry of EMI filter FILTANA TS 800 1005 is shown in Fig. 5. The EMI filter contains all types of components. So, we used a complete model that contains a model of resistors, capacitors and mutual inductance. In Fig 6 the full line shows measured curves and dotted line shows the equivalent curves obtained by simulation. From Fig 6 shows the measured curves are almost identical to the simulated curves.

Calculation of the optimization was facilitated by the assumption that the components same type have same values parasitic characteristics. For example parasitic characteristics capacitor 150 nF, which is in terminal  $N_1$ ,  $L_1$  are same as the capacitor, which is located at the terminal  $N_2$ ,  $L_2$ . The same is true of capacitors 3.3 nF. For this EMI filter we can use introduced model up to 100 MHz. At higher frequencies, this basic model will not achieve thus accurate results. The growing influence will be the interaction individual components and the PCB will influence the transmission of EMI filter.

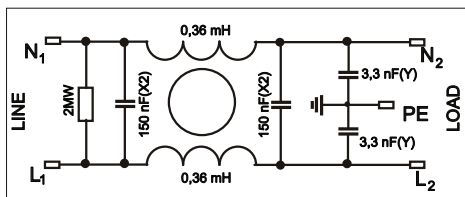

Fig. 5 Circuit schema EMI filter FILTANA TS 800 1005

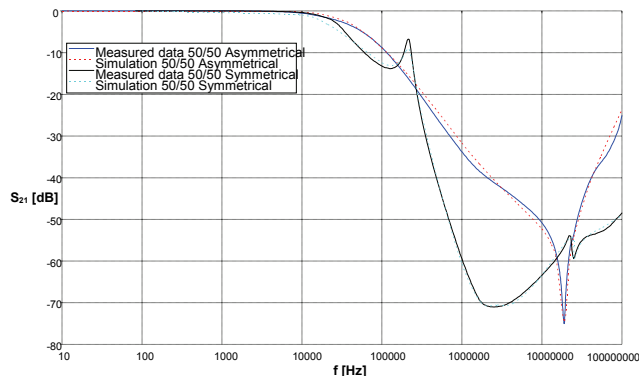

Fig. 6 Transmission EMI filter FILTANA TS 800 1005 in asymmetrical and symmetrical system.

Other EMI filter is selected ELFIS 1ELF16V its circuit schema is shown in fig. 7. The EMI filter contains all types of components. The model schema is fairly extensive and can not be shown in this paper. Each component is replaced by a model introduced in this paper. In Fig 8 he full line shows measured curves and dotted line shows the equivalent curves obtained by simulation. Again, the model was used for asymmetrical and symmetrical arrangement of measuring terminals. The measuring system was chosen  $50 \Omega / 50 \Omega$ . Asymmetrical arrangement achieves similar results as the previous filter. However, in the symmetrical measurement setup occurs a slight inaccuracy at

frequencies around 50 MHz, where the simulated curve no approximates the measured curve. In this case the EMI filter model can be used up to a frequency 100 MHz with minor inaccuracies.

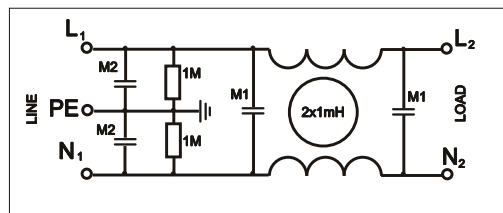

Fig. 7 Circuit schema EMI filter ELFIS 1ELF16V

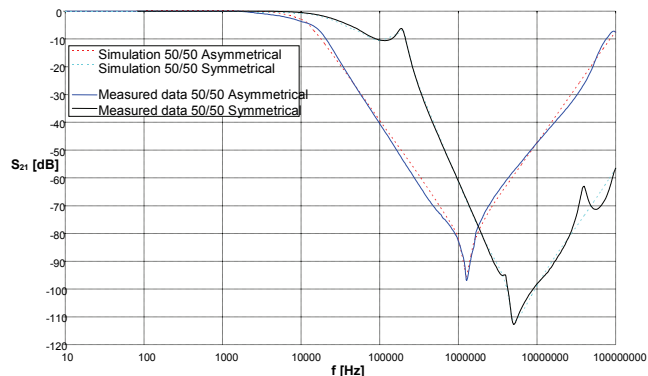

Fig. 8 Transmission EMI filter ELFIS 1ELF16V in asymmetrical and symmetrical system.

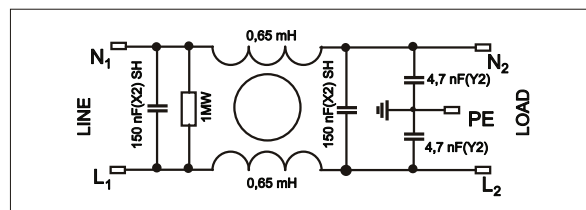

Fig. 9 Circuit schema EMI filter Schaffner FN 2020-16-06

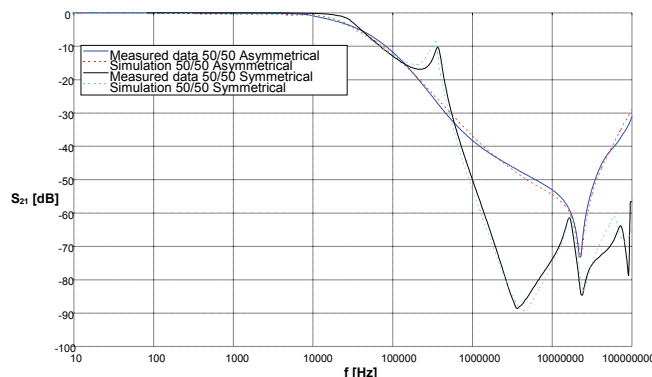

Fig. 10 Transmission EMI filter Schaffner FN 2020-16-06 in asymmetrical and symmetrical system.

The third selected EMI filter is the Schaffner FN 2020-16-06 circuit schema is shown in Fig. 9. The EMI filter contains all types of components. Terms of calculating spurious elements were same as in the previous case. The same measurement system was chosen. EMI filter has been tested again to asymmetrical interference and symmetrical interference. In Fig 10 the full line shows measured curves and dotted line shows the equivalent curves obtained by simulation. Results are very good for asymmetric system. For symmetric system there is a small

inaccuracy. The maximum inaccuracies occur again around frequency 50 MHz and above. In conclusion it is possible to declare that the models of the EMI filter are applicable to the frequency 100 MHz with a certain margin of error.

Last EMI filter is Schurter 5110.1033.1 its circuit schema is shown in Fig.11. The EMI filter does not contain resistor. In the model EMI filter is not necessary consider resistor properties. Furthermore, there is only one type of capacitor  $C_x$ . Model for EMI filter is the simplest of EMI filters selected. Conditions for determination of spurious elements are the same as in previous cases. The measurement system is again  $50 \Omega / 50 \Omega$ . In Fig 12 the full line shows measured curves and dotted line shows the equivalent curves obtained by simulation. In this case is minimum deviation. EMI filter model can be used up to 100 MHz.

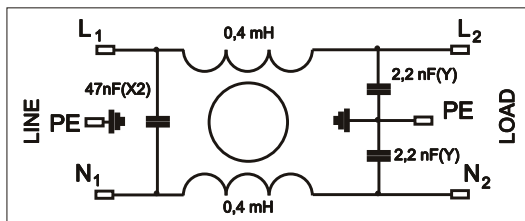

Fig.11 Circuit schema EMI filter Schurter 5110.1033.1

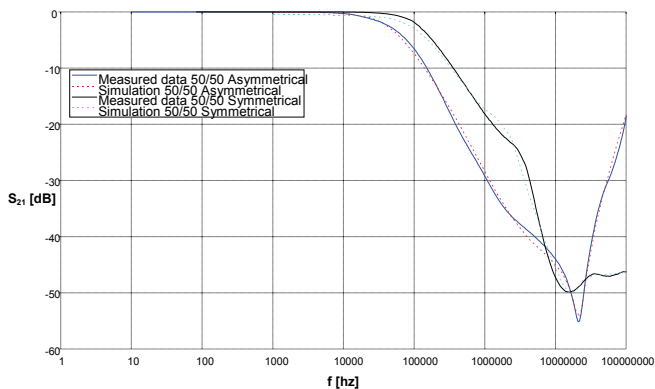

Fig. 12 Transmission EMI filter Schurter 5110.1033.1 in asymmetrical a symmetrical system.

All presented curves achieve good results. The proposed model is useful for estimation transmission EMI filter in range from 0 Hz to 100 MHz. At higher frequencies, EMI filter model is also affected by other parameters. The aim of the future work is to achieve broadband models which will not only estimation the transmission function, but also allows simulation in other measurement systems such as  $100 \Omega / 0.1 \Omega$  and  $0.1 \Omega / 100 \Omega$  [5]. These systems are already close to the worst case, which may occur in the energy supply network.

### Conclusion

This article was supposed to present a model of EMI filter, which is based on the spurious elements of individual

components. Introduced models based on the basic characteristics of component. At created model EMI filter was needed to determine value of spurious elements. These values were obtained by using optimization tools from Ansoft Designer software. The obtain values then were used to simulate in the same programming environment. The resulting values are compared with measured data. The figures show that proposed model of EMI filter achieves very good results. This model can be used for commercial EMI filters in the frequency range 0 Hz to 100 MHz. Another aim is to create a model that will achieve good results at higher frequencies.

### Acknowledgement

This paper has been prepared as the part of the solution of the grant no. 102/09/P215 "Advanced EMI filters Insertion Loss Performance Analyses in System with Uncertain Impedance Termination" of the Czech Science Foundation and grant No. 102/09/P215, by the Czech Ministry of Education by the research program MSM 0021630513 and specific research project FEKT-S-11-13 Innovative approaches for designing systems of communication chain.

### REFERENCES

- [1] ČSN CISPR 17: "Methods of Measurement of the Suppression Characteristics of Passive Radio Interference Filters and Suppression Components." Czech Technical Standard. Czech Normalization Institute. Prague, November 2000. 27 pages. (in Czech).
- [2] Liu,D.H.,Jiang,J.G. *High Frequency Characteristic Analysis of EM1 Filter in Switch Mode Power Supply (SMPS)*. Power Electronics Specialists Conference, 2002. pesc 02. 2002 IEEE 33rd Annual, Print ISBN: 0-7803-7262-X.
- [3] Kotny, L-J, Margueron, X, Idir, N. *High Frequency Modeling Method of EMI filters*. Energy Conversion Congress and Exposition, 2009. ECCE 2009. IEEE, Print ISBN: 978-1-4244-2893-9.
- [4] Wang; S, Lee, F, L, Odendaal, W, F, Wyk, J, D. *Improvement of EMI filter performance with parasitic coupling cancellation*. Power Electronics, IEEE Transactions on, Sept. 2005, ISSN 0885-8993.
- [5] KEJÍK, Z.; DŘÍNOVSKÝ, J.; RŮŽEK, V. *Estimation of the EMI Filter Circuitry from the Insertion Loss Characteristics*. Radioengineering. 2010. 19(2). p. 313 - 319. ISSN 1210-2512.
- [6] *Optimization Toolbox User's Guide*, [online], date of citation: 19.5.2011, available at [www.mathworks.com/help/releases/R13sp2/pdf\\_doc/opt/optim\\_tb.pdf](http://www.mathworks.com/help/releases/R13sp2/pdf_doc/opt/optim_tb.pdf).

**Authors:** Ing. Jiri Zachar, Ing. Jiri Drinovsky, PhD., Ing. Zdenek Kejik, Ing. Vaclav Ruzek, Department of Radio Electronics, Brno University of Technology, Purkynova 118, 612 00 Brno, Czech Republic,  
E-mail: xzacha00@stud.feec.vutbr.cz, drino@feec.vutbr.cz, xkejik01@stud.feec.vutbr.cz, xruzek00@stud.feec.vutbr.cz