

Interactions of partially conductive cracks with eddy currents in non-destructive evaluation

Abstract. The paper analyses interactions of induced eddy currents with partially conductive cracks using numerical calculations. A cracked plate specimen is non-destructively inspected using a standard procedure. Uncertainty in the crack depth estimation from the gained eddy current response signals is predicted. Enhanced evaluation of real partially conductive cracks is proposed according to the presented results.

Streszczenie. W artykule omówiono numeryczną symulację prądów wirowych w obecności częściowo przewodzących pęknięć materiału. Wzorcową płytkę z pęknięciem poddano standardowej procedurze testującej, po czym dokonano estymacji głębokości pęknięcia na podstawie wzmocnionego sygnału generowanego przez prądy wirowe w obecności defektu. Na podstawie analizy wyników zaproponowano rozszerzoną metodę ewaluacji rzeczywistych defektów częściowo przewodzących. (Numeryczna symulacja prądów wirowych w obecności częściowo przewodzących pęknięć materiału)

Keywords: non-destructive evaluation, eddy currents, partially conductive cracks, depth estimation

Słowa kluczowe: badania nieniszczące, prądy wirowe.

Introduction

Technological advancements, increasing complexity and price of modern machines results in increased consequences associated with possible component failures. Growing attention is focused towards machines' maintenance thereof. Early diagnosis can prevent human, material and economic losses.

Modern complex maintenance approaches include four phases – detection, evaluation, analysis and prediction. In case a degradation of construction material is detected, the extent thereof is evaluated along with influence on the behaviour of the whole system and future development. The first two phases are inherently associated with non-destructive evaluation (NDE) of materials while there is an intention to make the whole process fully automated. NDE methodologies are thus currently dynamically evolving.

Eddy current testing (ECT) is one of the widely utilized electromagnetic NDE methods [1]. It works based on an interaction of time-varying electromagnetic field with a conductive body according to the Faraday's electromagnetic induction law. Principle of the ECT underlies in the interaction of induced eddy currents with the conductive structure of an examined body [2]. The method possesses several benefits such as high sensitivity for surface breaking defects, high inspection speed, contactless inspection, versatility, maturity of numerical means, etc. These advantages determine continuously enlarging application area of the ECT mainly in nuclear, petrochemical and aviation industries. On the other hand, there is one particular disadvantage connected with the method. The ECT response signals are integral values and they do not carry explicit information about a crack. It means that ECT is the relative method and the inverse problem is ill-posed [3]. Therefore, evaluating dimensions of a detected defect from the ECT response signals can be quite difficult [4].

ECT instruments provide raw data with limited or absent capability of their quantitative interpretation [5]. Typically, evaluation relies on calibrated curves measured on pre-fabricated etalons and on the skills of an operator. Recently, the progress in powerful computers has allowed developing of automated procedures to make decisions. Two approaches are utilized in general; deterministic and stochastic methods are used for the purpose [4], [5]. The deterministic methods are the model based. They work according on difference minimization between measured and numerically predicted signals. The process is iterative and therefore large number of forward simulations is

required. The stochastic approaches simulate the mapping between eddy currents signals and defect profiles based on many known datasets. So called evolution algorithms, for example neural networks, genetic algorithms, etc. are utilized for the interpretation. Quite satisfactory results are reported by several groups for automated evaluation of artificial slits [4]. However, evaluation of real cracks, especially stress corrosion cracking (SCC), from ECT response signals remains still very difficult [6]. It has been found out that an SCC is partially conductive while its conductivity is not known in general and can vary from one case to another [7]. It is concluded that one of possible reasons is that actual eddy current sensors do not provide sufficient information for precise evaluation of SCCs [4].

The paper focuses on interferences between partially conductive cracks, as SCCs are, and eddy currents in NDE and investigates relations between the crack parameters and the response quantities. Uncertainty in crack depth evaluation from eddy current signals using a standard probe is appraised. New idea for increasing information content of sensed responses is proposed and numerically examined.

Numerical model

Numerical simulations are carried out to explore relations between the eddy current response signals and parameters of a partially conductive crack.

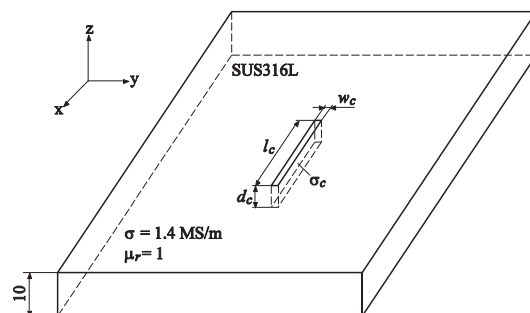

Fig. 1. Configuration and dimensions of plate specimen with crack

A plate specimen shown in Fig. 1 with a thickness of 10 mm is inspected in this study. The plate has the electromagnetic parameters of the stainless steel SUS316L; the material is frequently used for structural components in nuclear as well as in other industries.

A surface breaking crack of the rectangular shape appears in the middle of the plate. Three parameters of the

crack are varied in order to simulate variability of real cracks. The crack depth d_c is changed from 1 mm up to 10 mm with a step of 1 mm, its width w_c is adjusted to five values ranging from 0.2 mm until 1.0 mm with a step of 0.2 mm and the conductivity of cracked region σ_c is set to 0, 1, 2, 5, 10% of the base material conductivity. The only parameter that is kept constant for all the cases is the crack length of $l_c = 10$ mm.

A circular coil driven with the harmonic current under a frequency of 10 kHz induces eddy current in the specimen. The coil's axis is perpendicular to the plate's surface (normal position) and its dimensions are: outer diameter is 3.0 mm, inner diameter is 1.0 mm and height of the winding is 1.0 mm.

The response eddy current signals are predicted by the edge-element code and essential results are presented in the next sections.

Standard inspection

A pancake sensor is one of the most utilized for practical inspections. The sensor is of self-inductance absolute type, i.e. sensor is composed of only one coil that is the exciter and the detector at the same time. The coil is of circular shape and it is positioned normally regarding the surface of an inspected material, it means same as described in the previous section.

One dimensional eddy current response signal gained by scanning with the sensor just above an indicated crack along its length is taken as an input to the evaluation procedure. Mostly, three variables of the defect are estimated, its depth, length and position of its centre, while a profile, a width and the electromagnetic parameters of the defect have to be adjusted in advance. The present study assumes that the centre of crack, its profile as well as its length are fixed for all the simulated cases and thus only depth estimation is considered while a width and a partial conductivity of the crack are unknown.

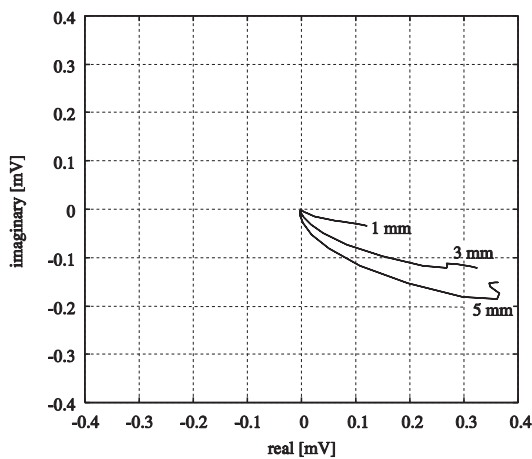

Fig.2. Crack response signals, $d_c = 1, 3, 5$ mm, $w_c = 0.2$ mm, $\sigma_c = 0\%$

Examples of calculated eddy current responses drawn in the complex plane are shown in Figs. 2-4. Figure 2 shows the response signals for the non-conductive crack with depths of $d_c = 1, 3, 5$ mm and a width of $w_c = 0.2$ mm. Similar results are displayed in Fig. 3. The crack has a depth of $d_c = 3$ mm, a width of $w_c = 0.2$ mm and conductivities of $\sigma_c = 0, 5$ and 10% of the base material conductivity. Influence of the crack width on the response signals for the partially conductive crack with a conductivity of $\sigma_c = 5\%$ of the base material conductivity and a depth of $d_c = 3$ mm is shown in Fig. 4. These results are gained for

the crack's widths of $w_c = 0.2, 0.6, 1.0$ mm. It can be seen that the response signal is quite complex variable of all the considered crack parameters.

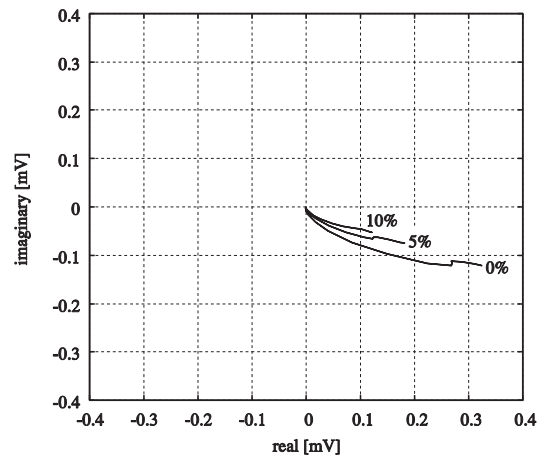

Fig.3. Crack response signals, $d_c = 3$ mm, $w_c = 0.2$ mm, $\sigma_c = 0, 5, 10\%$

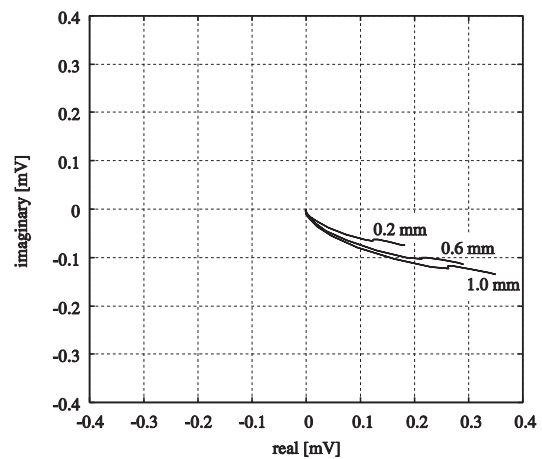

Fig.4. Crack response signals, $d_c = 3$ mm, $w_c = 0.2, 0.6, 1.0$ mm, $\sigma_c = 5\%$

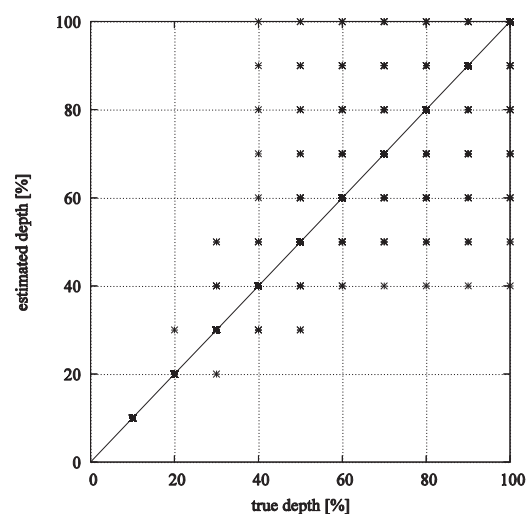

Fig.5. Uncertainty in crack's depth estimation, response signals are taken with the pancake sensor for one dimensional scan

Uncertainty in crack's depth estimation from eddy current response signals gained with the above mentioned probe is shown in Fig. 5. The full line corresponds to the ideal case when the estimated depth equals to the true one. The relation between the true and the estimated depth is represented by the stars. The relation is calculated in such a way that the response signals of the crack with two different configurations (depth, width, partial conductivity) are compared and when the difference between them is less than 1% such cracks are taken as having equal depth. One of the cracks is considered as an inspected one and the other as its model. All possible combinations of two responses from the whole set of predicted signals are treated in this way.

It is revealed that by using the standard probe and the standard procedures of inspection and evaluation under- or over- estimation of a crack's depth can occur with high probability when partially conductive cracks are considered.

Proposal of a new inspection procedure

The previous section clearly showed that the degree of uncertainty in depth evaluation of a partially conductive crack is quite high when the standard inspection procedure is performed using the standard probe. The reason is that the eddy current response signal does not provide sufficient information about the crack. The inverse problem of the crack's depth identification is highly ill-posed due to additional unknown crack's variables, i.e. its width and partial conductivity.

Any crack that occurs in a conductive material influences the path of eddy currents in a quite complicated way as their vector lines must be closed themselves. The changes in eddy currents' distribution create perturbations in the resulting electromagnetic field comparing to the no-crack situation. It has been proved that sensing only one spatial component of the perturbation electromagnetic field as the pancake sensor provide is not sufficient when partially conductive cracks are inspected.

The authors propose sensing all the three spatial components of the perturbation electromagnetic field to increase the information rate of eddy current response signals.

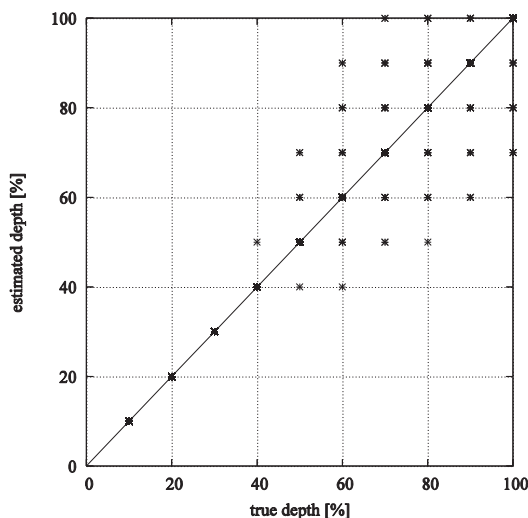

Fig.6. Uncertainty in crack's depth estimation, response signals of all three component for two dimensional scan are considered

Eddy current responses are numerically calculated under similar conditions as in the previous case. However, there are two differences concerning the sensor configuration and the scanning. The same coil as in the

previous section drives the eddy currents in the specimen. Three circular coils of same dimensions, i.e. the outer diameter equals to 4 mm, the inner one is set to 2 mm and the height of winding is 0.5 mm, sense the response signals independently. The coils are positioned perpendicularly to each other to sense all the three spatial components of the perturbation electromagnetic field. All the coils are centred at one point. Two dimensional scanning over the cracked region is realized. Uncertainty in the crack depth estimation is evaluated in the same way as in the previous section and the results are presented in Fig. 6. The presented results clearly prove that it is desirable to sense all the three spatial components of the perturbation electromagnetic field and to take signals of two dimensional scan over a cracked region when estimating dimensions of partially conductive cracks.

Conclusion

The paper dealt with eddy-current non-destructive evaluation of partially conductive cracks. Numerical simulations were carried out to predict eddy current response signals. A plate specimen having electromagnetic parameters of the stainless steel SUS316L was inspected. A near-side surface-breaking crack of rectangular shape was modelled in the middle of plate. Dimensions as well as partial conductivity of the crack were altered to simulate heterogeneity of natural cracks. At first, a standard pancake probe was used for the inspection. Only one dimensional scan just over the crack along its length was performed. The predicted crack's response signals were processed and it was shown that there is a high degree of uncertainty in crack's depth estimation due to partial conductivity of the crack. A new approach in sensing eddy current responses was then proposed. The idea is to sense all the three spatial components of the resulting electromagnetic field perturbed due to the presence of crack. It was proved that the new approach can essentially improve preciseness of crack's depth estimation when partially conductive cracks are inspected.

Acknowledgement

This work was supported by the Slovak Research and Development Agency under the contract No. APVV-0194-07. This work was also supported by a grant of the Slovak Grant Agency VEGA, project No. 1/0308/08.

REFERENCES

- [1] Rao B.P.C., Practical eddy current testing, Oxford: Alpha Science International Ltd., 2007, ISBN 978-1-84265-299-2.
- [2] Janoušek L., Čápková K., Gombárska D., Smetana M., Progress in eddy-current non-destructive evaluation of conductive materials, *ACTA TECHNICA CSAV*, 55 (2010), No. 1, 13-28.
- [3] Yusa N., Huang H., Miya K., Numerical evaluation of the ill-posedness of eddy current problems to size real cracks, *NDT&E International*, 40 (2007), 185-191.
- [4] Yusa N., Development of computational inversion techniques to size cracks from eddy current signals, *Nondestructive testing and evaluation*, 24 (2009), 39-52.
- [5] Rubinacci G., Tamburino A., Ventre S., Fast numerical techniques for electromagnetic nondestructive evaluation, *Nondestructive Testing and Evaluation*, 24 (2009), 165-194.
- [6] Yusa N., Janoušek L., Rebican M., Chen Z., Miya K., Dohi N., Chigusa N., Matsumoto Y., Caution when applying eddy current inversion to stress corrosion cracking, *Nuclear Engineering and Design*, 236 (2006), 211-221.
- [7] Yusa N., Miya K., Discussion on the equivalent conductivity and resistance of stress corrosion cracks in eddy current simulations, *NDT&E International*, 42 (2009), 9-15.

Authors: doc. Ing. Ladislav Janoušek, PhD., Ing. Milan Smetana, PhD., Ing. Marcel Alman, Department of Electromagnetic and Biomedical Engineering, Faculty of Electrical Engineering, University of Žilina, Univerzitná 1, 010 26 Žilina, Slovak Republic, E-mails: {janousek, smetana, alman}@fel.uniza.sk