

# Recovery voltage in ZnO ceramics

**Abstract.** The paper presents short review of non-ohmic ceramics properties with respect to four energy conversion in the material bulk. Recovery voltage response is shown as phenomena that origins in that conversion. Modelling of ZnO ceramic sample in pre-breakdown area by means of linear dielectrics for the purpose of polarisation analysis is described. Recovery voltage responses of new and thermally aged samples are measured and differences in time domain are shown. Results are discussed.

**Streszczenie.** Artykuł przedstawia przegląd właściwości ceramiki z nieliniową rezystancją. Przede wszystkim analizowane jest napięcie powrotne. Opisano analizę polaryzacji ceramiki ZnO. Zbadano napięcie powrotne próbek nowych i starzonych. (Napięcie powrotne w ceramice ZnO)

**Keywords:** ZnO ceramics, recovery voltage.

**Słowa kluczowe:** ceramika ZnO, napięcie powrotne.

## Introduction

Non-ohmic ceramic, mainly composed on ZnO crystals, are used widely in huge amount of application fields. The capabilities of energy absorption and non-linear current-voltage characteristics are related to their structure, which is formed during annealing the ZnO substrate with small amount of another metal-oxides e.g. Bi<sub>2</sub>O<sub>3</sub>, Sb<sub>2</sub>O<sub>3</sub>, Cr<sub>2</sub>O<sub>3</sub>, NiO etc. Non-linearity of V-I characteristics depends grain-boundary properties. It has been found that the breakdown voltage of 3V is there for single non-ohmic grain-boundary [1].

The piezoelectric behaviour of crystals is in the centre of research interest for a long time and models have been developed. Generally, piezoelectricity couples the mechanical stress and strain fields with the electric intensity and displacement fields. Relations between various energy forms have been explained by means of several scientific models. Tutorial on piezoelectric and related phenomena and the history on this topic can be found in interesting paper of Arthur Balato [2]. The early model, as mentioned in previous reference, was developed by Heckmann in 1925. It includes physical effects related to energy conversions among mechanical, electric and thermal energies. Next, the model has been improved by light item and new – Thurston’s model has been established. The energy relations can be found e.g. in [3]. Based on these two models, magnetics formalisms have been added. So, derived model contains four kinds of energies: magnetic, electric, thermal and stress, see Fig. 1.

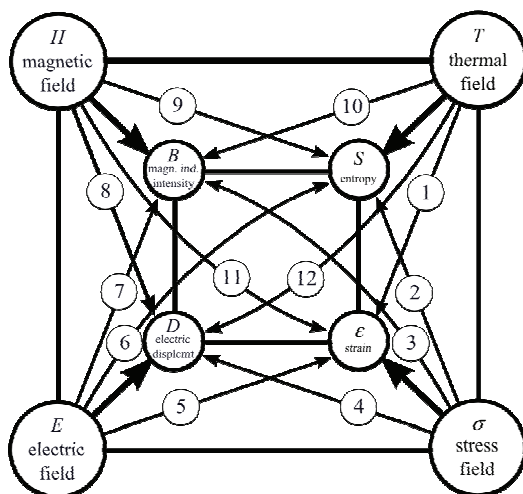

Fig. 1. General four energy conversion diagram in crystals [4]

In the Fig. 1, there are two squares with angles marked. Outer square is marked by general energies, inner square by basic or principal effects. The arrowed lines mean related effects according the following number key: 1 – thermo-elastic effect, 2 – elasto-thermal effect, 3 – elasto-magnetic effect, 4 – elasto-electric effect, 5 – electro-elastic effect, 6 – electro-thermal effect, 7 – electro-magnetic effect, 8 – magneto-electric effect, 9 – magneto-thermal effect, 10 – thermo-magnetic effect, 11 – magneto-elastic effect and finally 12 – thermo-electric effect. The energy balance is given by the form [4]:

$$(1) \quad G = U - T \cdot S - \sigma \varepsilon - E \cdot D - H \cdot B$$

where  $G$  is free energy density and  $U$  is internal energy density.  $T$  is temperature,  $S$  is the entropy. Thermal energy density is given by multiplication  $T \cdot S$ .  $\sigma \varepsilon$  is mechanical energy density.  $E$  and  $D$  are the vectors of electric intensity and electric displacement and  $E \cdot D$  is electric energy density.  $H$  is intensity of magnetic field and  $B$  is magnetic inductive intensity. The  $H \cdot B$  is magnetic energy density. Note, that the model is universal so any physical phenomena and related effect can be derived. It follows that polarisation phenomena are coupled with electric energy density  $E \cdot D$ .

If large energy barrier is supposed, the ZnO crystal is of dielectric behaviour. The microscopic displacement of the coupled to the atoms charges, determines the dielectric characteristics behaviour of the material. The dielectric polarization is related to the existence of atomic and molecular forces. It is caused by charges displacement in material under the influence of an electric field.

## Recovery voltage – the polarisation response

Recovery voltage is coupled with polarisation phenomena. For decades, a lot of scientific efforts have been spent to shift-forward the knowledge about dielectric polarization spectra. The methods are based on either frequency or time domain polarization measurements. In frequency domain the complex permittivity is determined from amplitude and phase shift of the current when sinusoidal test voltage is applied. In case of time-domain measurements, the voltage step is applied on the object and small polarization/depolarization currents are measured. The dielectric response as consequence of Debye polarizations in the dielectric material is analyzed by modelling the dielectric function as an exponential function. Generally, the polarization phenomena can be studied using Recovery Voltage Measurements (RVM) and Polarization Current Measurements (PCM), too.

One of known application areas is the condition assessment of dielectric material related to its aging. Whilst in [5] authors wrote about polarization spectra as new

method, the overall insight has grown up commonly with the development of a number of methods which give detailed information about space charge distributions across dielectrics [6]. The diversity of research has led to a number of theoretically based models that could lead to get the necessary aging indicators. Dielectric behaviour of the insulating system by circuit model has been modelled e.g. [7]. Special research activity was spent by analyzing of frequency domain of dielectric response. It has been named by the term dielectric spectroscopy.

The RVM and PCM measurements have took important place in insulating systems reliability assessing. It is generally known that RVM has become popular due to it's widely spread condition assessment of power transformer insulation by power utilities. Besides that, successful was research of dielectric response of MICA based material which plays important role in h.v. rotated machines production [8]. Results of the research have lead to dielectric materials innovations. The combination of micro and nano-metric sized silica grain in epoxy based compounds was utilized in a comparative study to establish their dielectric behaviour [9].

The principle of the RVM method has been adapted and re-published by many authors all around the world e.g. [5, 10, 11, 12, 13, 14] and many others. On the one side RVM offers a lot of advantages which include non-intrusive testing, easy to operate procedure, more noise-resistant performance compare to other nonintrusive diagnostic methods. However, the lack of understanding on the physical process causes dispute over interpretation of measurement results. For a long time the difficulty lies right with the accurate interpretation of return voltage results. Therefore special attention has been given on different interpretation schemes [13]. Traditionally, polarization model has been implemented as parallel RC circuit, see Fig. 2. Recovery voltage response, is also called as 'polarization spectrum' as each time constant corresponds approximately to single relaxation time constant given by  $R_i C_i$  multiplication. Dominant time constants are considered in the model. The  $R_0$  is responsible for leakage current modelling. It can be quantified by known dc conductivity.  $C_\infty$  is 'high frequency' capacitance. Its value is determinable by conventional methods.

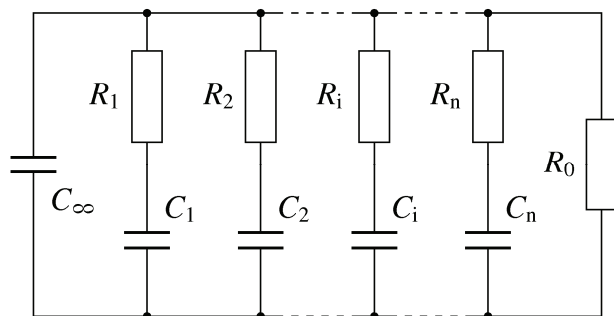

Fig. 2. Equivalent circuit for modelling of bulk nano-composite in non-conducting state

However, it was found that the model is not sufficient, because of inter-facial charge movement. The new model and instrumentation have been suggested [15, 16]. The unique properties of real objects, e.g. cables, h.v. transformers, rotated machines etc., need to be taken into account. The correlation between time and frequency domain has been shown for several times e.g. [17]. By the following the timeline of the topics, it can be discovered, that parameterization of the problem has arrived. The effect of the several parameters such as water content, object

geometry, aging state was determined [18]. Dominating impact on dielectric response is related to temperature of the object rather than its geometry [19].

Properties of nano-ceramic composites are concerned with the aspect of processing, in particular managing of grain growth during sintering. Recovery voltage origins in depolarization of dipoles, discharging of grain boundaries and space charge effect [20]. In this case, the RVM is considered as efficient tool to monitoring degradation in applied nano-composites in heavy-load applications.

The behaviour of dielectric response can be predicted. It is meaningful always, when the tracing of aging future can reach important economical recovery. The necessary aging indicators for power apparatus in interconnected network can be unleashed by RVM and PCM [21].

Nano-composites, especially nano-ceramics, belong to some of compound groups. It was shown that these compounds assume the polytypism, so the given compound can assume more than one crystalline structure, as mentioned in [22]. The phenomenon coupled with the type and grain size of base compound material (e.g. ZnO, SiC, etc.) and additives with respect of thermal processes – this is cause of the varying of the bandgap (approximately from 2 to 4 eV) and relative permittivity, too (approximately from 8 to 130). Under bandgap limit, the nano-composite can be considered of linear dielectric behaviour. This is also called as early pre-breakdown current density region. With respect to the grain boundary junctions, the bulk polarisation can be assumed.

Let us briefly describe how the recovery phenomena can be studied. The model has been already introduced in the Fig. 2. It can be used for nano-composite sample presentation. The sample is suddenly charged with unipolar voltage  $V_c$  for the certain time  $T_c$ . Depending on the time of voltage application, the polarizations as represented by  $R_i C_i$  branches are activated. Some of them are fully activated and some of them are activated only partially. Now, the sample is grounded for short period  $T_d$ , so  $C_\infty$  capacitance is totally discharged. After grounding releasing, the slower polarizations start to relax. The recovery voltage  $v_r$  traces polarisation relaxations. Under open circuit conditions, the recovery voltage can be measured. The magnitude  $V_{r \max}$  of recovery voltage is always proportional to  $V_c$ . Besides, it depends on charging time and grounding period, too. The slope  $s_{v_r}$  of the return voltage is proportional to the polarisation which is active in instant  $t_2$ . Graphical interpretation of the RVM principle is in the Fig. 3.

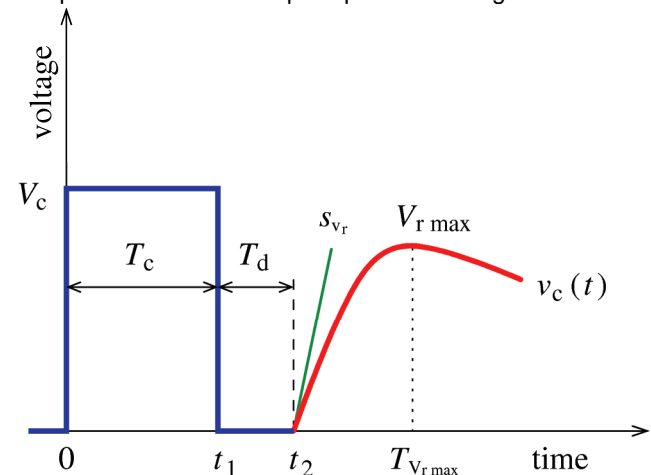

Fig. 3. The principle of RVM

Exact expression of the paragraph above is possible by using maths. During sample is charged the voltage on

capacitors is rising. In the time instant  $t_1$ , the voltage over the capacitance  $C_i$  reaches value of

$$(1) \quad v_{ci}(t_1) = V_c \cdot \left( 1 - \exp\left(\frac{-t_1}{R_i C_i}\right) \right).$$

In the time instant  $t_2$ , remaining voltage on capacitance  $C_i$  can be derived by the following form:

$$(2) \quad v_{ci}(t_2) = V_c \cdot \left( 1 - \exp\left(\frac{-t_1}{R_i C_i}\right) \right) \cdot \exp\left(\frac{-t_2}{R_i C_i}\right).$$

Each capacitance in the model presented is recovered with own time constant and voltage transients occur. There are recoveries of four polarisations. Voltages  $v_{C1}$ ,  $v_{C2}$ ,  $v_{C3}$ ,  $v_{C4}$  as they change on capacitances in the simulation procedure and overall voltage transient are shown in the Fig. 4. There are graphical analysis of all three stages – the charging, discharging and recovering and voltage transients on four model-included capacitors are shown separately.

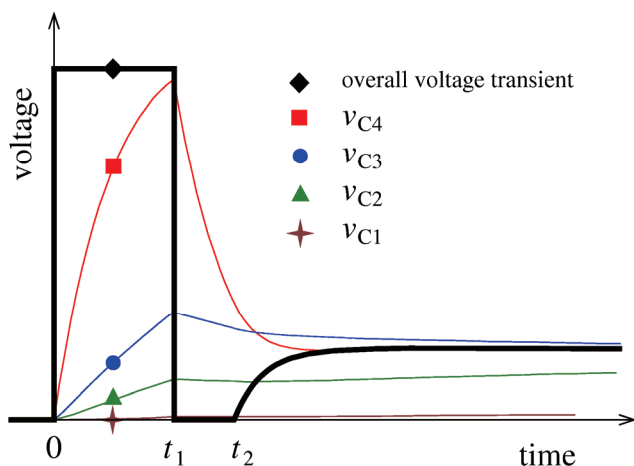

Fig. 4. The polarization simulation in model with four polarizations

### Experimental

The goal of experimental was to get polarisation characteristics of the sample by the means of recovery voltage transients. The recovery was measured in ZnO disc, which are commercially shipped. In the production, the standard annealing process has been applied on ZnO vapour and rare earths additions. Geometry of the disc follows: thickness of  $2.018 \pm 0.003$  mm and diameter of  $13.89 \pm 0.01$  mm.

The recovery voltage was measured directly on the disc, which become the sample object, see Fig. 5. The scheme presented contains DC high voltage source, a set of three controlled switches and voltmeter connected to the sample object. There are special requirements on electrical properties of the voltmeter and the relay no. 2. The key property of the both is high input resistance because of leakage elimination. Note that general-used instruments do not meet such property. In the frame of the experiment, the generating voltmeter and vacuum relay have been used.

The timing has been controlled by the programmable interface and transients have been recorded to the computer for post-processing and analysis. The galvanic coupling between measuring circuit and control centre was eliminated by means of opto-couplers. According previous findings of the scientists, the timing was established as: charging time  $T_c = 100$  s, discharging time  $T_d = 2$  s and recovery voltage measurement period was 300 s.

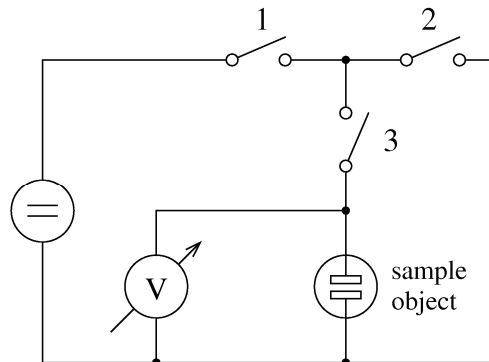

Fig. 5. Electrical scheme for recovery voltage measurements

### Results and discussion

Two samples were measured. The first one was ZnO disc in virgin state and the second one the same kind of ZnO disc but thermally aged for 1980 hours at temperature  $105^\circ\text{C}$ . The results are presented in tabular form and graphically, too. In the Fig. 6, there are recovery response records at charge voltage levels of 200 V and 300 V, which have been selected for presentation of the shape and timing characteristics of the ZnO samples.

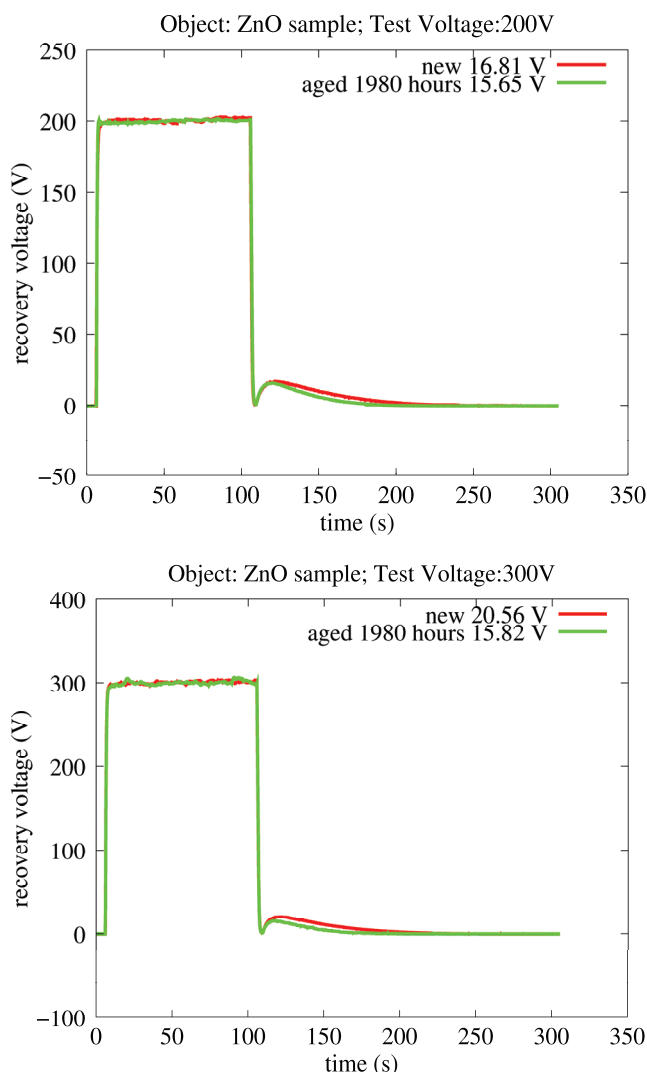

Fig. 6. Recovery response of new and aged ZnO discs with applied voltage of 200 V and 300 V, respectively

Detailed specific values of recovery maximum, computed as average value from minimal three records per voltage level, are shown in the Table 1.

Table 1. Maximal value of recovery voltage transients of new and aged ZnO discs

| Voltage applied during charging period (V) | $V_{r \max}$ on new ZnO disk (V) | $V_{r \max}$ on aged ZnO disk (V) |
|--|----------------------------------|-----------------------------------|
| 200  | 16.81                            | 15.65                             |
| 250  | 20.00                            | 13.94                             |
| 300  | 20.56                            | 15.82                             |
| 350  | 22.24                            | 16.78                             |

## Conclusions

Recovery voltage phenomena in ZnO crystals have been shown. Moreover, the significant differences have been uncovered, when the response was measured in new and aged sample, respectively. Differences of the magnitude  $V_{r \max}$  of recovery voltages have been measured for new and aged samples. In the future works, the analysis of the slope  $s_{V_r}$  and recovery period will be done. Results show that ZnO samples are of linear dielectric behaviour in pre-breakdown conditions. Measuring of recovery voltage response can be used as tool for monitoring of ZnO products aging.

## Acknowledgment



We support research activities in Slovakia / Project is co-financed from EU funds. This paper was developed within the Project "Centrum excelentnosti integrovaného výskumu a využitia progresívnych materiálov a technológií v oblasti automobilovej elektroniky", ITMS 26220120055

## REFERENCES

- Bernik S, Daneu N. Characteristics of SnO<sub>2</sub>-doped ZnO-based varistor ceramics. *Journal of the European Ceramic Society*. (2001); 21(10–11):1879–1882.
- Ballato A. Piezoelectricity: old effect, new thrusts., *IEEE Transactions on Ultrasonics, Ferroelectrics and Frequency Control*. DOI – 10.1109/58.464826. (1995); 42(5):916–926.
- Baoyuan S, Jiantong W, Jun Z, Min Q. A new model describing physical effects in crystals: the diagrammatic and analytic methods for macro-phenomenological theory. *Journal of Materials Processing Technology*, (2003), 139(1-3):444–447.
- Khalid O. Investigation on Dielectric Constant of Zinc Oxide. *Journ. of mod. appl. Sc.* (2009); 3(2):110–116.
- Osvath, P., Zahn, H. Polarisation spectrum analysis for diagnosis of oil/paper insulation systems. In: *IEEE International Symposium on Electrical Insulation*, Pittsburgh, PA USA, June 5-8, (1994), pp. 155–161
- Ahmed, N. H., Srinivas, N. N.. Review of space charge measurements in dielectrics., *IEEE Transactions on Dielectrics and Electrical Insulation*, (1997). Vol. 4, No. 5, pp. 644–656.
- Saha, T. K., Middleton, R., Thomas, A. Understanding frequency & time domain polarisation methods for the insulation condition assessment of power transformers. In: *IEEE Power & Energy Society General Meeting*, (2009), pp. 1–8.
- Cimbala, R. The calculation of polarization spectrum and activation energy of insulation during accelerated thermal stress. *Acta Electrotechnica et Informatica*, (2006). 6(2), 1–4.
- Castellon, J., Agnel, S., Tourelle, A., Fréchette, M. F., Savoie, S., Krivda, A., et al. Space charge behaviour on epoxy based dielectrics filled with micro and nano silica. In: *Proc. of 10<sup>th</sup> IEEE International Conference on Solid Dielectrics (ICSD)*, (2010). pp. 1–4.
- Seifert, J. M., Stietzel, U., & Karner, H. C. The ageing of composite insulating materials-new possibilities to detect and to classify ageing phenomena with dielectric diagnostic tools. In: *Electrical Insulation*, (1998). Conference Record of the IEEE International Symposium on Electrical Insulation (pp. 373–377 vol.2).
- van Bolhuis, J. P., Gulski, E., Smit, J. J., Urbani, G. M., Verhaart, H. F. A. Development of knowledge rules for RVM for interpretation of the condition of transformer insulation. Conference Record of the *IEEE International Symposium on Electrical Insulation*, (2000), pp. 267–270.
- Lu, Y. H., Tan, C. K., Phung, B. T., Khawaja, R. H., Blackburn, T. R. Development of a computer-based data logger for recovery voltage measurements. Conference record of *The Australasian Universities Power Engineering Conference*, Monash University – Melbourne Sept 29 – Oct 2, 2002. Monash University – Melbourne, (2002).
- Saha, T. K. Review of Time-Domain Polarization Measurements for Assessing Insulation Condition in Aged Transformers. In: *IEEE Transaction on Power Delivery*, (2003), 18(4), 1293–1301.
- Cimbala, R., Kolcunova, I., Krsnak, I. Current Response of Insulation Systems Based on ReMica Materials and Accelerated Thermal Degradation. In: *Iranian journal of electrical and computer engineering*, (2004), 3(1).
- Kuang, Y. C., Chen, G., Jarman, P. Recovery voltage measurement on oil-paper insulation with simple geometry and controlled environment. Conference record of *The IEEE International Conference on Solid Dielectrics*, July 5-9, 2004, Toulouse, France. (2004), pp. 739–742.
- Kuang, Y. C., Chen G., Jarman, P. A new model for recovery voltage of oil-paper insulation system. Conference record of *The IEEE International Conference on Solid Dielectrics*, July 5-9, Toulouse, France. (2004), pp. 582–585.
- Saha, T. K., Middleton, R., Thomas, A. Correlation between time and frequency domain polarisation measurements for transformer moisture assessment. In: *Australasian Universities Power Engineering Conference (AUPEC 2004)*, (2004).
- Shayegani, A. A., Mohseni, H., Borsi, H., Gockenbach, E. Diagnostics of Power Transformers with Dielectric Response Measurements. Conference record of *The 20<sup>th</sup> International Power System Conference (PSC) – Iran, Tehran*, (2005).
- Koch, M., Feser, K. Reliability and influences on dielectric diagnostic methods to evaluate the ageing state of oil-paper insulations. Conference record of *II International Conference on Advances in Processing, Testing and Application of Dielectric Materials, 15-17 September, Wrocław 2004*. In: *Prace Naukowe Instytutu Podstaw Elektrotechniki i Elektrotechnologii Politechniki Wrocławskiej. Konferencje* (2004), Vol. 40, nr. 15, pp. 95–101.
- Mardira, K. P., Saha, T. K., Sutton, R. A. Investigation of Diagnostic Techniques for Metal Oxide Surge Arresters. In: *IEEE Transactions on Dielectrics and Electrical Insulation*, (2005). 12(1), pp. 50–59.
- Birlasekaran, S., Xingzhou, Y. Relaxation studies on power equipment. In: *IEEE Transactions on Dielectrics and Electrical Insulation*, (2003), 10(6), pp. 1061–1077.
- Kurimsky, J., Dolnik, B. On stability of polarisation current pattern during forced thermal aging in sintered ceramics. In: *Prz. Elektrotechniczny*, (2010), 86(9), pp. 257–261.

**Authors:** Ing. Juraj Kurimský, PhD Technical University of Košice, Dept. of Electric Power Engineering, Mäsiarska 74, Košice, SK-04001, E-mail: juraj.kurimsky@tuke.sk ; Dr. Ing. Bystrík Dolník, Technical University of Košice, Dept. of Electric Power Engineering, Mäsiarska 74, Košice, SK-04001, E-mail: bystrik.dolnik@tuke.sk