

Design and Implementation of a ZigBee-Based Wireless Automatic Meter Reading System

Abstract. ZigBee is a new global standard for wireless communications with the characteristics of low-cost, low power consumption, and low data rate. It has a good market in wireless meter reading. The design and implementation of a ZigBee-based wireless automatic meter reading system are proposed in this paper. The experimental results show that the design can meet the basic needs of automatic meter reading with flexibility and expansibility. It can act as a platform of wireless monitor system and supplies a new hardware design approach for wireless ZigBee networks.

Streszczenie. Zaproponowano wykorzystanie sieci bezprzewodowej ZigBee do automatycznego odczytu stanów liczników. (Projekt i zastosowanie sieci ZigBee do automatycznego odczytu stanów liczników)

Keywords: ZigBee, Wireless communications, Automatic meter reading system

Słowa kluczowe: ZigBee, liczniki energii

Introduction

With the rapid development of automation and measuring techniques, automatic recording of the data in the meter reading instrument has gradually become the target of people whose working, living, and home conditions are of increasingly high level of intelligence. Meanwhile, utilities also hope that the development of new technologies to solve the problems they encountered in the practical work about cumbersome meter reading and no reliable protection of accuracy and real time; and enable both user-friendly and improving public sector efficiency and management level. Existing wire-line meter reading system has a large number of risks. Wires are more complex, detrimental to adjustment and maintenance of the system. The long-term indoor and outdoor installation easily leads to aging, resulting in a risk of short circuit and breakage. For these reasons, it has become the industry very unresolved problem to design a remote meter reading system, with long-term reliance and convenient installation & maintenance, which not only read data automatically but also monitor operation status.

With the development of wireless communication technology, in recent years there comes requirement for low cost equipment of wireless networking technology, called ZigBee. It is a short range, low-complexity, low cost, low power consumption, low data rate two-way wireless communication technology with high network capacity, short time delay, safety and reliance. Its main application areas include industrial controls, consumer electronics, car automation, agricultural automation, and medical equipment control. The core of this technology is established by IEEE 802.15.4 Working Group, and the ZigBee Alliance founded in 2002 is responsible for high-level applications, interoperability testing, and marketing. Till now, the ZigBee Alliance has reached over 150 members of famous companies in the world including IBM, Ember, Mitsubishi, Motorola, and Philips, etc [1]. Many semiconductor companies are targeting the ZigBee market. Since the standards were launched not long ago, chips in line with protocol have been available of multi-chip solution and single-chip solution. It can be expected that ZigBee will have comprehensive applications in the field of automation.

The main methods of metering at home and abroad are: manual meter reading, IC Card prepaid meter, wire-line and wireless meter reading system. Manual meter reading has been for decades, but with the implementation of one home one meter, drawbacks of this method of reading are more and more, like difficult entrance to home, low efficiency of fee settlement, etc. Along with the development electronic technology, IC card prepaid meter, which uses pay-before-

use, favors to management sector. Since it does not need meter reading on site, partially solve the problem of manual meter reading because of no need to be on site. But some problems exist in the actual operation process: IC card meter is easily damaged due to its direct contact with user and no real-time monitoring. It also fails to avoid theft, damage, and fault of meter. Wire-line metering control system has the advantage of IC card, and at the same time can take full advantage of telephone network, power line network, a cable TV network, and RS-485 bus net, etc. It enables real-time metering, real-time monitoring, and real-time control, and can also detect equipment damage, illegal use, etc. But there are some issues: piping, cable wiring, so it needs to design in advance. In addition, it also has problems of long construction period, high installation cost and maintenance cost, expansion of the system upgrade and compatibility with other network.

ZigBee wireless meter reading refers to the use of short-range wireless communication technology and computer network technologies to read and process metering data automatically. Wireless automatic meter reading technology can not only save human resources, but more importantly may improve the accuracy and real time of the meter, enabling management sector to access to data messages timely and accurately. No cable wiring can save human and material resources, so investment is considerably economical. Wireless communication links can be quickly built, engineering cycle significantly shortened, and has better scalability compared to a wire-line system [2,3]. If a fault occurs, only check wireless data module for causes quickly, and then restore the system back to normal operation[1].

ZigBee Wireless Sensor Networks

ZigBee technology is a bidirectional wireless communication technology of short distance, low complexity, low cost, low power consumption, and low data rate, mainly used in automatic control. It mainly works on 2.4GHz ISM band with 20~250kbit/s data rate, 100m~1.5km maximum transmission range, and a typical 100m distance [4]. The technical features include:

- (1) Security: ZigBee provides data integrity check and authentication, and uses AES-128 security algorithm. Each application has the flexibility to determine its safety properties.
- (2) Reliability: It uses collision avoidance mechanism, and at the same time it reserves a dedicated time slot to require a fixed bandwidth of the communication service, avoid the competition and conflicts when data is sent. MAC layer uses a full confirmation of data

transfer mechanisms, and each packet of data sent must wait to receive confirmation.

- (3) Low cost: the initial cost of module estimates about US\$6, and soon will fall between US\$1.5 and US\$2.5, and ZigBee Protocol is free of royalties.
- (4) Power saving: as the duty cycle is very short, transmitting and receiving information has lower power consumption, and using the hibernation mode, ZigBee technology ensures that two N size batteries can support from 6 months to 2 years. Of course, different applications have power different power consumptions.
- (5) High network capacity: a ZigBee network can accommodate a maximum of 65536 devices.
- (6) Short delays: enhanced communication delays for delay-sensitive applications. Communication delay and sleep wake up time delay are very short. Typical device search delay is 30ms, typical sleep wake up time delay is 15ms, and active channel access delay is 15ms.

Main applications of ZigBee are within short range and data transfer rate among the various electronic equipments is not high. The typical transfer data types are periodical data (such as sensor data), intermittent data (such as lighting control), and repetitive low latency data (such as a mouse).

Because Bluetooth, Wi-Fi, and ZigBee all belong to 802.15 protocols, technical characteristics have many similarities. Characteristics comparison is shown in Table 1. Since transmission distance of Bluetooth and Wi-Fi is less than 100m, it is a huge obstacle in the larger network. Thus it is difficult to form wireless communication network, while the maximum transmission range of ZigBee is 100m ~1.5km, which is ideal for the establishment of the network. Secondly, it can only accommodate up to 8 nodes in a Bluetooth network, but a typical network needs more devices nodes, and ZigBee can accommodate 65536 nodes. Finally, module costs of Bluetooth and Wi-Fi are relatively high. In addition, the power consumption of Bluetooth and Wi-Fi compared to ZigBee is much higher, because ZigBee is low cost and very low power consumption. Although transmission data rate of Bluetooth and Wi-Fi is higher than that of ZigBee. But the 250kbit/s data rate of ZigBee is enough for use in automatic meter reading network, thus the ZigBee technology is selected.

Table 1. Performance comparison of ZigBee, Bluetooth, and Wi-Fi

Performance	ZigBee	Bluetooth	Wi-Fi
Working frequency	2.4GHz、868/915MHz	2.4GHz	2.4GHz
System resource	4Kbyte~32Kbyte	250Kbyte	1Mbyte
Comm. range	0.1~1.5km	0.1km	0.1km
Data rate	250 Kbps	1Mbps	11Mbps
Max. network nodes	65536	8	32
Wake-up time	30ms	10s	3s
Encryption	128 bits AES	128 bits	SSID
Low power consumption	Support	No support	No support

Typical Topology of Wireless Meter Reading System in ZigBee Network

ZigBee network supports star, cluster tree, and mesh network architectures as shown in Fig. 1 [1]. ZigBee network has self-organizing and self-healing capabilities, and supports complex network topology, making message

communicate among nodes in the network via different routes. Network not only has good scalability, but also makes data transmission more reliable. Multiple subnets can be connected at the same time to form a large, geographically dispersed network, making cross-zone metering and control be easily achieved.

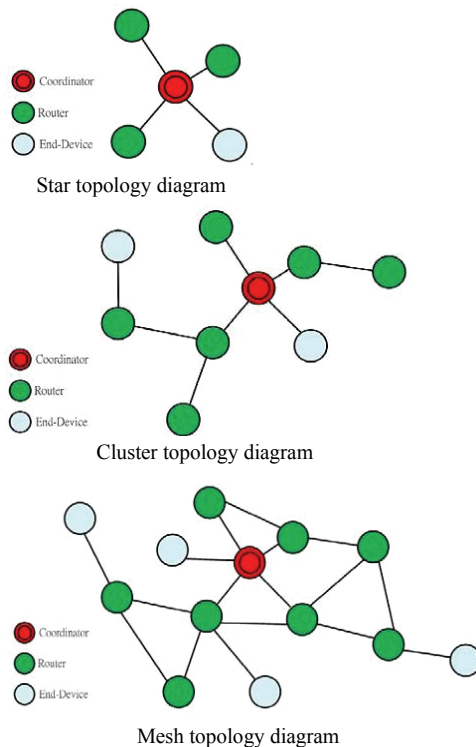

Fig.1. Typical ZigBee network architecture

System Structure

The wireless automatic meter reading system described in this article can send data from a number of digital watt meters to the collector through RS-485 communication protocol, and transfer the data to ZigBee/GPRS Gateways through ZigBee Wireless communication network, then back to PC or the database in RS-232 communication format via GPRS as shown in Fig. 2. The wireless communication network in the middle uses JN5121 ZigBee modules produced by Jennic Company in combination with G-4500 GPRS remote communication devices developed by ICP DAS, forming a wireless communication network.

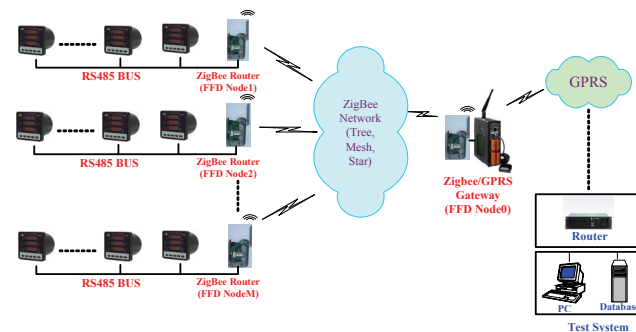

Fig.2. System structure of wireless automatic meter reading system

Complete ZigBee protocols consist of the high-level application specification, application aggregation layer, network layer, data link layer and physical layer, as in Fig. 3. Protocols above network layer are defined by ZigBee Alliance, and IEEE 802.15.4 is responsible for the physical layer and link layer standards [5-10].

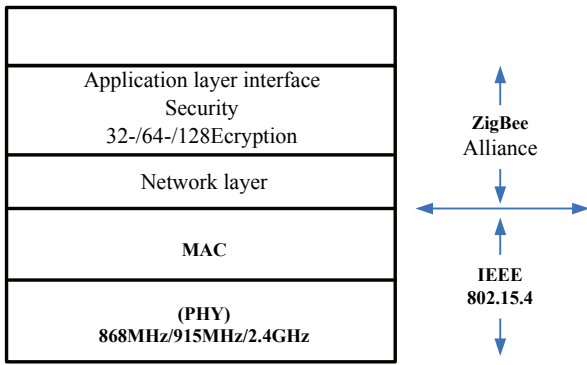

Fig.3. ZigBee protocol stack

The physical layer defines the access between wireless physical channels and MAC sub-layer, and provides physical layer data service and physical layer management service. Main functions of a physical layer data service are: wake/sleep of RF transceiver devices, energy tests on the current channel, link quality instruction, carrier sense multiple access with collision avoidance (CSMA-CA) for assessment of spatial channel, channel selection, data transmission and reception.

IEEE 802.15.4 defines two physical layer standards for choices, but both are based on direct sequence spread spectrum technology, namely 2.4GHz Physical layer and 868/915MHz physical layer. They use the same physical layer data packet format, but differ by working frequency, modulation, spread spectrum code length and transfer rate.

2.4GHz Band is ISM Band for the global unification without the application, help ZigBee equipment with promotion and reduction of production costs. 2.4GHz physical layer can deliver transfer rate of 250kb/s through the use of higher-order modulation technology, help to achieve higher throughput, less communication delays and shorter duty cycles and thus more power saving.

915MHz is ISM band in the United States, and 868MHz is ISM band in Europe. The two bands were introduced to avoid 2.4GHz mutual interference of various wireless communication equipments in the vicinity. The transfer rate is 20kb/s in 868MHz band, in 916MHz band with a rate of 40kb/s. Because the wireless signal propagation loss on these two bands is smaller, so the requirement for receiver sensitivity can be decreased, so that effective communication distance can be farther and fewer devices can be used to cover a given area.

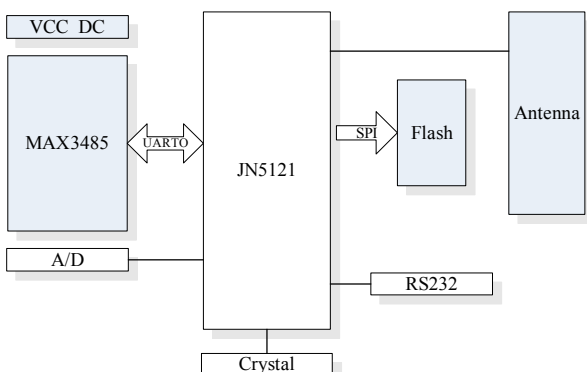

Fig.4. Hardware block diagram of external terminal module

External terminal node module is mainly used for upgrade and improvement of existing electric meter network. The electric meter has RS-485 bus interface. Main tasks of the module are to access, read, and write the

electric meter. Fig. 4 is the hardware block diagram of external terminal node.

In order to communicate with meters, there is a chip for conversion of voltage level because the electric meter communication interface is RS-485. This article will use MAX3485 chip, making it compatible with voltage level of JN5121 [11-17].

Metering System Software Design

ZigBee end device reads energy measurement information in multifunction electric meter by UART, and transmits them to the network coordinator via ZigBee wireless network, thus it can realize the wireless meter reading of the network coordinator. Meanwhile, the network coordinator can transfer clock-correcting command to multifunction electric meter through ZigBee end device to calibrate the system clock and power parameters. Therefore, the end device must be able to communicate with the multifunction electric meter in order to read data and the coordinator in order to send data. The coordinator also has to know which end node that sends the data so the data can be read accurately. Each of ZigBee modules has a unique 64-bit permanent address, so the addressing won't be much difficult. Fig. 5 shows the program flowchart of end device.

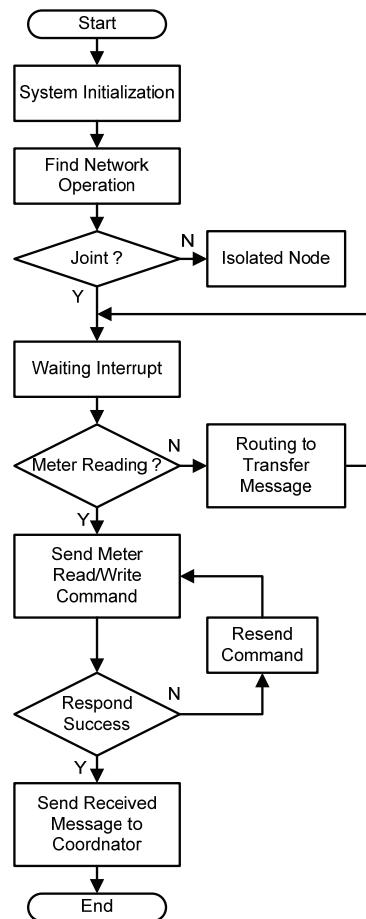

Fig.5. Program flowchart of ZigBee end device

A TI's ZigBee2006 protocol stack, Z-Stack, is transplanted in CC2430. Z-Stack protocol stack contains an operating system abstraction layer (OSAL) that performs scheduling task in Z-Stack [11]. Therefore, the understanding of OSAL mechanism is a prerequisite of ZigBee product development. OSAL is a mechanism for task allocation of resources, thus to form a simple multi-

tasking operating system. Fig. 6 shows the OSAL workflow. Before entering the main loop of the operating system, system initialization is particularly significant in the preparations. The operating system initialization needs to perform a function `osal_init_system()`. This function can initialize memory allocation system, message queue, timer for OSAL, power management system, tasks system, and task list. The start function of the operating system, `osal_start_system()`, is in the end of the main function. This function is the main cycle of the task system and it visits all the task events and calls the appropriate event. If there is no event which includes all of the tasks, this function allows the processor to enter sleep mode and then has no return value. Start function find whether the task events happened in accordance with the priority of the missions. It indicates the occurred task event through the implementation of `osalNextActiveTask()` function, and performs the corresponding task processing function.

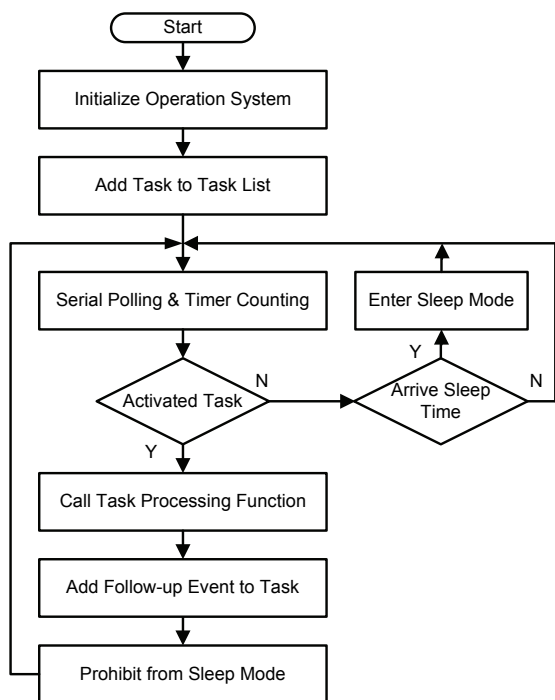

Fig.6. Flowchart of operating system abstraction layer



Fig.7. Monitoring and management interface of wireless automatic meter reading system

The monitoring and management interface of the wireless automatic meter reading system in this research is shown in Fig. 7. It is coded with the Visual Basic Program language developed by Microsoft. As a data receiver, it receives multifunction electric meter data including voltage, current, active power, power factor, and watt-hours. The communication port number on which the coordinator connects and the baud rate of the protocol can also be set

on the interface. The automatic meter reading system considerably reduces both the difficulty of meter reading and human resources. Moreover, it also significantly improved the accuracy and instantaneity of data collection due to the use of digitalized management.

Experiment Results

This article is to verify the feasibility of wireless automatic meter reading system based on ZigBee by implementing a wireless automatic meter device as shown in Fig. 8. A multifunctional digital electric meter, cement load, ZigBee modules, and on/off switches are installed on top of a wood board of 30x30 (cm).



Fig.8. Wireless automatic meter device

The electric meter measures electrical parameters and transfers measured data to ZigBee Concentrator via RS-485 to RS-232 communication ports and to ZigBee/GPRS Gateway via wireless communications network, then to a terminal node via GPRS and back to PC in RS-232 communication format to complete the automatically wireless meter system, as shown in Fig. 9.

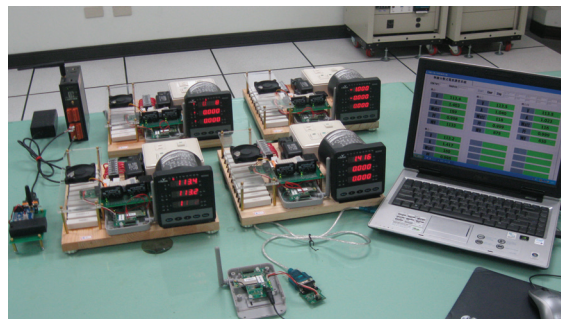

Fig.9. Wireless automatic meter reading system

Four wireless automatic metering end devices are installed in Management Hall, Kuo-Xiu Building, Library and Information Hall, and Chin-Yun Hall of National Chin-Yi University of Technology, respectively. An coordinator and a GPRS devices are placed in Engineering Hall, with distance of approximate 300M, 260M, 110M, and 150M respectively, as shown in Fig. 10.

This study tested the network setup time of wireless automatic meter reading system. The average result of 100 tests is within 4 seconds. Network-wide circular meter reading time from single point of view is 5 seconds on average; single point meter reading average success rate is above 98%; single point meter re-reading success rate is 100%, within the interval of 30 seconds. On the remote on/off control, a single on and off control is within 3 seconds, and its success rate is 100%. And other wireless communication interference to meter and control has no significant impact, as shown in Table 2.

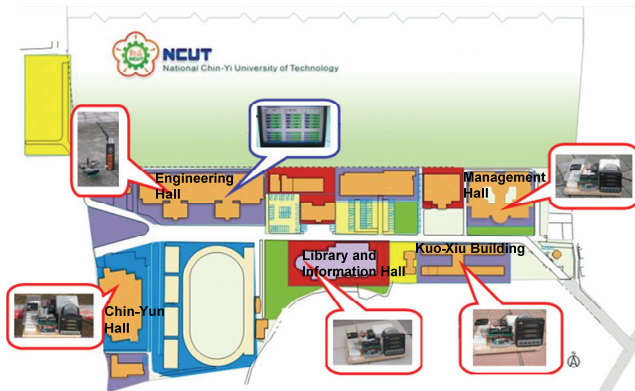

Fig.10. Installation location for wireless automatic meter reading system

Table 2. Tested results of critical performance index

Test Conditions		Test Results	Remarks
Network setup time		<4 Sec.	
Results of network-wide circular meter reading	Average time of single point meter reading	<5 Sec.	Circular meter reading 100 times
	Success rate of single point meter reading	>98%	
	Success rate of single point meter re-reading	100%	Time interval 30 Sec.
Remote ON/OFF control	ON control time	<3 Sec.	Continuous control 10 times
	Success rate of single time ON	100%	
	OFF control time	<3 Sec.	Time interval 30 Sec.
	Success rate of single time OFF	100%	
Effects of other wireless communication interference to meter and control	IEEE 802.11b/g	-*	
	Bluetooth	-*	
	GSM/GPRS	-*	

*: No obvious effect

Conclusion

The successful development of the wireless automatic meter reading system described in this article is based on the high performance, extremely low power consumption, high level of integration, and low price of ZigBee technology. The technology has strong market competitiveness. ZigBee wireless meter reading system uses short-range wireless communication and computer network technologies to read and process metering data automatically. Wireless automatic meter reading technology can not only save human resources, but also improve the accuracy and instantaneity of the meter reading. It enables management sector to timely and accurately access power consumption

messages. Moreover, no cabling is required with relatively economical investment. For the proposed wireless automatic meter reading system, wireless communication links can be quickly built, engineering period significantly shortened, and it has better scalability compared to a wired system. If a fault occurs, simply checking wireless data module can quickly find it out and restore the system in normal operation.

Acknowledgements The research was supported by the National Science Council of the Republic of China, under Grant No. NSC 98-2622-E-167-010-CC3, and the Ministry of Education, Taiwan, R.O.C., under grant 100E-70-025 of Industry-Academic Cooperation Project.

REFERENCES

- [1] Safaric S., Malaric K., ZigBee Wireless Standard, *Proc. of the 48th International Symposium ELMAR-2006*, Zadar Croatia, 1 (2006), 259-262
- [2] Primitanta, A.H., Nayan, M.Y., Awan, M., ZigBee-GSM based Automatic Meter Reading system, *2010 International Conference on Intelligent and Advanced Systems (ICIAS)*, Kuala Lumpur, Malaysia, 1 (2010), 1-5
- [3] Tatsiopoulou, C., Ktena, A., A Smart ZIGBEE Based Wireless Sensor Meter System, *16th International Conference on Systems, Signals and Image Processing (IWSSIP)*, Chalkida, Greece, 1 (2009), 1-4
- [4] Lee J.D., Nam K.Y., Jeong S.H., Choi S.B., Ryoo H.S., Kim D.K., Development of ZigBee Based Street Light Control System, *Proc. of the Power System Conference and Exposition*, Atlanta GA, 3 (2006), 2236-2240
- [5] IEEE 802.15 WPAN Task Group 1 (TG1), <http://www.ieee802.org/15/pub/TG1.html>
- [6] IEEE 802.15 WPAN Task Group 2 (TG2), <http://www.ieee802.org/15/pub/TG2.html>
- [7] IEEE 802.15 WPAN Task Group 3 (TG3), <http://www.ieee802.org/15/pub/TG3.html>
- [8] IEEE 802.15 WPAN Task Group 4 (TG4), <http://www.ieee802.org/15/pub/TG4.html>
- [9] ZigBee Alliance · <http://www.ZigBee.org/>.
- [10] Chen Z., Lin C., Wen H., Yin H., An Analytical Model for Evaluating IEEE 802.15.4 CSMA/CA Protocol in Low-Rate Wireless Application, *Proc. of the 21st International Conference on Advanced Information Networking and Applications Workshops*, 2 (2007), 899-904
- [11] JENNIC JN5121 Hardware Peripheral API Reference Manual, Revision 0.7, (2005)
- [12] JENNIC JN5121-EK000 Board Hardware API Reference Manual, Revision 0.4, (2005)
- [13] JENNIC JEK01 Demonstration Application Code description, Revision 0.5, (2005)
- [14] JENNIC 802.15.4 MAC Software Reference Manual, Revision 0.7, (2005)
- [15] JENNIC JN5121-EK000 Demonstration Application User Guide, Revision 0.4, (2005)
- [16] JENNIC Software Developers KIT Installation Guide, Revision 0.2, (2005)
- [17] JENNIC Debugging with DDD, Revision 3.3.9, (2004)

Authors:

Ph.D. Hung-Cheng Chen, National Chin-Yi University of Technology, Department of Electrical Engineering, Taiping Dist., Taichung 411, Taiwan. E-mail: hcchen@ncut.edu.tw.
 Master Long-Yi Chang, National Chin-Yi University of Technology, Department of Electrical Engineering, Taiping Dist., Taichung 411, Taiwan. E-mail: lychang@ncut.edu.tw.