

Experimental measurement of parameters of the spatial scanner Hokuyo URG - 04LX

Abstract. The contribution is devoted to the evaluation of measurements of the spatial parameters of a laser scanner. Its physical dimensions enable placement on a mobile robotic platform, to measure the orientation and movement in space. The article provides a procedure for verifying basic operating parameters of the URG-04LX Hokuyo sensor as reported by the manufacturer.

Streszczenie. W artykule przedstawiono wyniki testów laserowego skanera przestrzennego Hokuyo URG-04LX. Analiza ma na celu wykorzystanie skanera w robotyce. (**Eksperymentalna analiza parametrów skanera przestrzennego Hokuyo URG-04LX**)

Keywords: laser scanner Hokuyo URG-04LX, mobile robotic platform, the range of detection, optical encoder, communication protocol.
Słowa kluczowe: przestrzenny skaner laserowy.

Introduction

Laser scanning is a method that allows the contactless measurement of spatial objects can be based on spatial or polar triangulation method. The basic characteristics of this method are high speed data collection reaching several thousand points per second while maintaining high accuracy. The result of this measurement is the amount of points, by which the measured object is captured.

Description of spatial scanner Hokuyo URG-04LX

URG-04LX Hokuyo is a laser rangefinder, which belongs to the category of sensors with amplitude modulated continuous wave. Laser emits a laser beam whose direction is controlled by the rotating mirror, and reaches the surface of the scanned object from which is then reflected. The source of the sensor makes use of an infrared laser with a wavelength of 785 nm [6]. Laser safety class falls under # 1 according to IEC. The amplitude of the emitted light is modulated at frequencies 46.55 MHz and 53.2 MHz. Motor sensor rotates 600 revolutions per minute so that the measured data have been spotted within period of 100 ms. The maximum possible measurable distance is 4095 mm with an accuracy of ± 10 mm measurement range between 20 to 1000 mm, or $\pm 2\%$ at distances greater than 1000 mm. Detection range is at an angle of 240° with an approximate resolution of 0.36° . External dimensions are 50x50x70 mm laser, weight 170 grams.

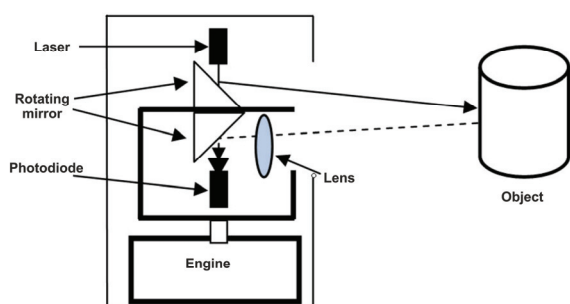

Fig.1. Functional scheme of the laser scanner

Under the receiving photodiode laser there is an optical encoder, which controls the angular rotation of mirrors. For this sensor two computational units are used. One engine on the top engines of the optical part, the second at the bottom of the sensor for the management and control circuits. The computing device on top of the sensor features automatic power management circuits. Main clock frequency of 13.3 MHz is transformed into a cluster of

signals with frequencies of 46.55 and 53.2 MHz clocks are also designed with 90 degrees phase difference of the carrying a frequency of 49.875 MHz value. Clusters of signals are supplied to the circuit while the clock laser used in the A / D converter to sample data. Two A / D converters used for measuring distances are supplied with data on the waves of the photodiode circuit. The data signals are supplied to the standard A / D converter. The first converter is processing data during reception while the second is performing it after transfer. They are synchronized and sampled through hours and then sent to a circuit for digital computation. Optical encoder is used to determine the angular position of rotating mirror, detects the position of brands on a rotating metal disk which is under the photodiode. Data from encoder are sent to the circuit measuring the angle and then supplied to the main computer unit.

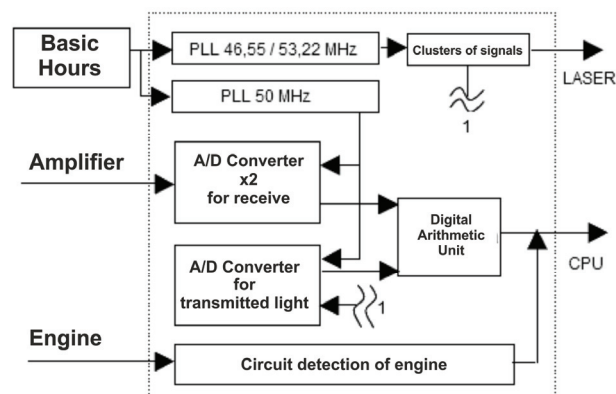

Fig.2. The principal scheme of system ASIC

Communication protocol of scanner URG-04LX

System instructions labeled SCIP is developed by Hokuyo using laser scanners for mobile robots and platforms [3]. The terminal device sends a group of commands to achieve the desired information, the sensor responds with information with relevance to the command. The SCIP system of commands is based on the ASCII, which has a special method to express the 16-bit data into the three characters and 12 bit data as two characters. Hokuyo URG-04LX laser scanner is able to measure up to a maximum distance of 4095 mm, the distance of the communication protocol can be divided into two 1 - byte characters [5]. Systems Command in SCIP is set as default properties which are used for communication between the terminal, e.g. a PC, and a sensor to create a variety of tasks and settings. This specification is used to describe the system

commands defined in the SCIP communication protocol version 2.0. In order to use this communication protocol, the sensor must be upgraded to a compatible firmware.

The device is equipped with external interfaces USB and RS232C, communication between the sensor and endpoint devices may be traceable through any of them. Angular resolution scanner is 0.3515625° per step, step number 0 is represents by number 384 and 768 corresponding the to angles of the sensor -135° , 0° and $+135^\circ$ with respect to the front axis of the reference point of measurement. The maximum possible angular measurement of the sensor is 240° , between steps 44 and 725.

The minimum measurable distance is 20 mm; the data are expressed in 12 bits and encoded in two characters. It means that 6 bits are converted into a single character, in order to reduce the amount of data. A twelve-bit number is divided into two six-bit numbers and are added by the number of 30H [4, 8].

Description of the program and the application environment

The script is designed to ensure communication between the Matlab software and the URG-04LX laser scanner using libraries. At the initial state, the program informs ton the function of the script he office by using the GET_DISTANCE written in C to perform individual measurements. The basic display is an option the total number of measurements. After completing the measurements program provides a number of summarizing information about the measurements as:

- the total number of measured samples
- time for which the measurement was made
- minimum measured value
- maximum measured value
- the average in the format \pm
- indication of the standard deviation
- indication of the dispersion
- median

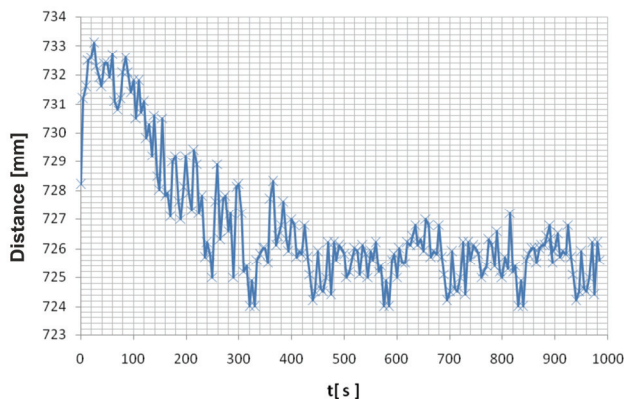

Fig.3. Measurement of time for stable sensor measurements

Description of measuring workplace

The workplace consisted of measuring the optical bench, which accounted for 2 and a half meters long metal platform which was placed a runner with a grip on the measured object. At the beginning of the measuring platform there is a laser scanner fixed by a special anchorage. The management and control member is made up of a laptop featuring a pre-installed open-source Linux. Choosing this system set up communication with the Matlab software. Power sensor was mediated by a stabilized power supply to BS 554 which was set constant 5V supply voltage.

Measurement of time for stable sensor measurement

The aim of this measurement is to determine the time needed from power on laser for steady measurements, included in this measurement is the so-called laser heating. Measured object with a paper surface was set to a distance of 700 mm and 10 000 measurements of samples were performed.

The measurement results demonstrate that the sensor has stabilized its measurement after 10 minutes of sampling. During this time, this error was 4.20%, whereas after this time, the average value of the relative measurement error 3.66%.

Distance Measurement

The role of the measurement was to determine how they can affect the evaluation of the measured distance laser scanner different types of surface material being measured. For the purposes of measurement were selected three types of surface material being measured:

- aluminum foil with a polished surface
- paper
- wallpaper with rough surface

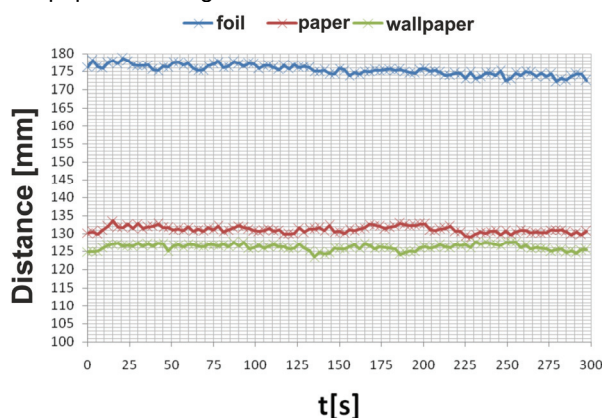

Fig.4. Dependence of the measured object distance on time for the distance of 100 mm

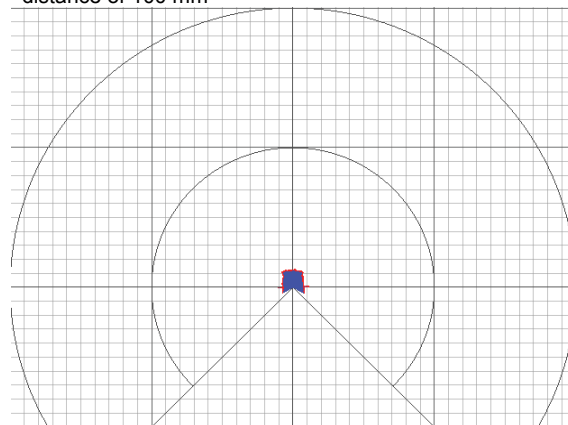

Fig.5. View URG Viewer software for object distance 100 mm

These materials were mounted on a plastic plate attached to the runner of the optical bench. In the basic position, the object measured was firstly located 100 mm from the scanner, then 500 mm, and the last measurement was made at a distance of 1500 mm from the sensor. Each measurement lasted 300 seconds, between each measurement were 3 seconds and 100 measurements were made. In each position, 1000 samples were processed by means of which it is possible to calculate the measured distance, and errors incurred in measurements such as standard deviation or variance of the measurement. The subsequent measured data can help evaluate how the

surface of the object measured affects the distance measurement by laser scanner on the whole.

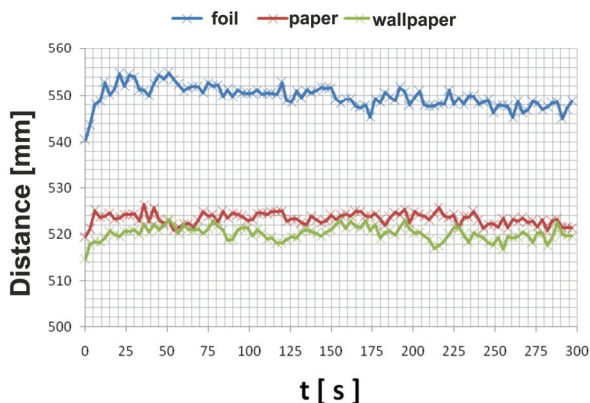

Fig.6 The dependence of the measured object distance on time for the distance 500 mm

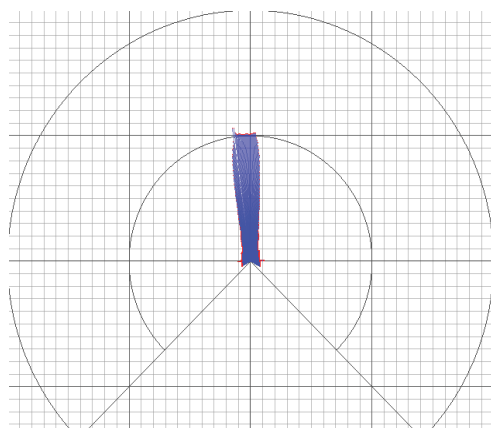

Fig.7 View URG Viewer software for object distance 500 mm

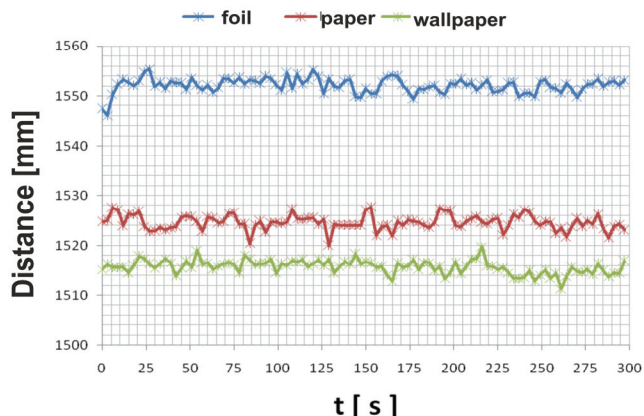

Fig.8 The dependence of the measured object distance on time for the distance 1500 mm

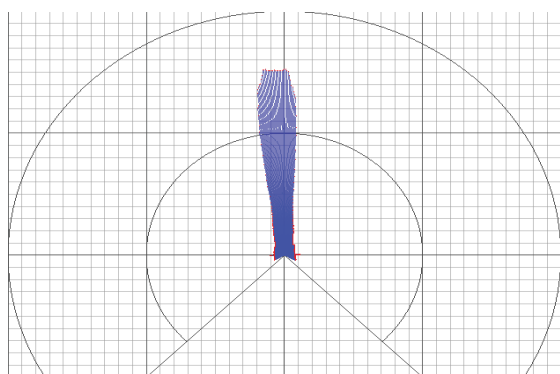

Fig.9 View URG Viewer software for object distance 1500 mm

Evaluation of distance measurement errors

The evaluation of scanner parameters was based on the measurement of the absolute measurement error [8], which is defined as the difference between the measured N and the true value measured. Then followed the evaluation of the relative measurement error, which is equal to the difference between the absolute error Δ and the actually measured S .

Table1. Errors of measurement evaluated for the object distance of 100 mm.

The surface wallpaper, the distance 100 mm			
Gauge	Δ [mm]	δ [mm]	δ [%]
124,80	24,800	0,248	24,80
124,90	24,900	0,249	24,90
125,00	25,000	0,250	25,00
125,90	25,900	0,259	25,90
126,70	26,700	0,267	26,70
127,00	27,000	0,270	27,00
127,20	27,200	0,272	27,20
126,50	26,500	0,265	26,50
126,60	26,600	0,266	26,60
126,40	26,400	0,264	26,40

Table 2. Errors of measurement evaluated for the object distance of 500 mm.

The surface wallpaper, the distance 500 mm			
Gauge	Δ [mm]	δ [mm]	δ [%]
514,60	14,600	0,029	2,920
518,00	18,000	0,036	3,600
518,50	18,500	0,037	3,700
518,40	18,400	0,037	3,680
519,30	19,300	0,039	3,860
520,80	20,800	0,042	4,160
520,00	20,000	0,040	4,000
519,60	19,600	0,039	3,920
520,60	20,600	0,041	4,120

Table 3. Errors of measurement evaluated for the object distance of 1500 mm.

The surface wallpaper, the distance 1500 mm			
Gauge	Δ [mm]	δ [mm]	δ [%]
1515,20	15,200	0,010	1,013
1516,20	16,200	0,011	1,080
1515,60	15,600	0,010	1,040
1515,60	15,600	0,010	1,040
1515,70	15,700	0,010	1,047
1514,50	14,500	0,010	0,967
1516,10	16,100	0,011	1,073
1517,90	17,900	0,012	1,193
1517,40	17,400	0,012	1,160
1516,40	16,400	0,011	1,093

Conclusion

Evaluation of the experimental measurement of the Hokuyo URG-04LX spatial distance laser scanner demonstrates the suitability of using this type of sensor in the field of robotics and robotic platforms. In the article and communications environment has been tested and a communication protocol was developed for experimental measurements to verify the information supplied by the manufacturer regarding the accuracy of measuring distances. For measuring three different surfaces of the measured object were used. The largest uncertainties have been found when measuring the distance of foil polished surfaces. These uncertainties can be analyzed by stochastic method presented in [5]. The error of measurement was significantly reduced when measuring the distance of the object with other surfaces. The best results as regards the accuracy were obtained by the object

with a wallpaper surface where the relative error fluctuated around 27%. The highest accuracy was achieved when measuring the distance the object with wallpaper surface, its actual distance from the laser was 1500 mm. In this measurement, the maximum relative error was around 1% level. On the basis of experimental measurements carried out and evaluation of measurement results it is possible to evaluate the accuracy of the described laser scanner as claimed by the manufacturer in the technical description [1, 2, 7].

REFERENCES

- [1] Okubo, Yoichi - YE, Cang - BORENSTEIN, Johann: Charakterization of the Hokuyo URG-04LXX Laser Rangefinder for mobile robot obstacle negotiation, Unmanned Systems Technology XI. Edited by Gerhart, Grant R.; Gage, Douglas W.; Shoemaker, Charles M.. Proceedings of the SPIE, Volume 7332 (2009)., pp. 733212-733212-10 (2009).
- [2] Range-finder type laser scanner URG-04LX Specifications Available at: <http://www.hokuyo-aut.jp/>
- [3] Kawata, Hirohiko - URG - Series Communication Protocol Specification (SCIP version 2.0 Available at: <http://www.hokuyo-aut.jp/>
- [4] Hirohiko Kawata, Wagle Santosh, Toshihiro Mori, Akihisa Ohya and Shin'ichi Yuta: "Development of ultra-small lightweight optical range sensor system", Proceedings 2005 IEEE/RSJ International Conference on Intelligent Robots and Systems, pp.3277-3282 (Aug. 2005).
- [5] Sotak, M.: Determining stochastic parameters using an unified method. In: Acta Electrotechnica et Informatica. - ISSN 1335-8243, Vol. 9, No. 2 (2009), p. 59-63.
- [6] Tottori SANYO Electric Co., Ltd : Infrared Laser Diode DL - 3144- 007S, ver.1, May.2001 Available at: <http://www.princetel.com/datasheets/>
- [7] Kmec, F.; Králík, V.; Soták M.: Cenovo dostupný laserový skener pre mobilné platformy. In: AT&P journal, ISSN 1335-2237, Vol. 16, No. 9 (2009), p. 60-62.
- [8] Králík, V.; Soták M.: Laser rangefinder orientation. In: MOSATT 2009: modern safety technologies in transportation : proceedings of the international scientific conference: 22nd-24th September 2009, Zlata Idka, (2009), ISBN 978-80-970202-0-0, p. 153-157.

Author: Ing. PhD. Róbert Bréda, Technical university Košice, Faculty of Aeronautics, Department of Avionics, Rampová 7, 04021 Košice, Slovakia, E-mail: robert.breda@tuke.sk