

A novel approach to measurement of permeability of magnetic fluids

Abstract. This paper deals with problems of permeability measurement of magnetic fluids. The low permeability of magnetic fluids bring certain problems to adequately measure their magnetic properties due to leakage flux, their liquid state makes the process even more difficult. Our approach to measure the permeability and measured properties of several fluids is presented.

Streszczenie. W artykule analizowano możliwość pomiaru przenikalności cieczy magnetycznych. Problemem są: mała przenikalność, duże strumienie rozproszenia, stan płynny. Zaprezentowano metodę pomiaru na przykładzie kilku cieczy. (Metoda pomiaru przenikalności cieczy magnetycznych)

Keywords: Ferrofluids, magnetic fluids, magnetorheological fluids, low permeability measurement.

Słowa kluczowe: ciecze magnetyczne, pomiar przenikalności.

Introduction

Several technical applications using unique properties of magnetic fluids are currently being developed, e.g. [1, 2]. Producers of magnetic fluids usually do not guarantee – and often even do not publish – the physical characteristics of magnetic fluids and designers of these devices are left on their own measurements. Most important parameters of magnetic fluids are their magnetic properties and their magneto-viscous characteristics.

Measurement methods of ferromagnetic solids are described in detail, e.g. [3], but these methods cannot be used for ferromagnetic liquids. They have the following specific magnetic properties:

- very low relative permeability
- their hysteresis properties are negligible
- their magnetic nonlinearity manifests not until rather high magnetization values

An important property is the magnetic permeability. Different forms of permeability in isotropic environment (e.g. reversible permeability, incremental permeability) merge into single property defined by the ratio B/H , see, e.g. [4].

Magnetic liquids represent relatively complex physical environment. If no external magnetic field is influencing the magnetic liquid (i.e. magnetic field intensity $H = 0$), the magnetic liquid is isotropic, while if $H > 0$, the fluid shows anisotropy, and this anisotropy grows with higher values of H . Under low values of H the magnetic fluid is linear, while under higher values of H the magnetic saturation appears and brings about nonlinearity. Magnetic liquids are homogenous under $H = 0$, but with higher H chains of ferromagnetic nanoparticles are built up in the microstructure of the fluid. These structures act as local non-homogeneities. If an external non-homogenous magnetic field acts on the liquid, higher concentration of these chains of nanoparticles evolves in areas with higher values of H and the magnetic fluid acts as magnetically non-homogenous. Especially, if the external magnetic field is homogenous, the magnetic fluid is magnetically homogenous as well.

A relation between the vector of magnetic induction B and the vector of magnetic intensity H is valid in a magnetic fluid:

$$(1) \quad B = \bar{\mu}H$$

where $\bar{\mu}$ is the tensor of permeability.

Elements of this tensor of permeability are given by the relation $\mu_{ij} = \mu_{ij}(H, x, y, z)$; $i, j = 1, 2, 3$. The analysis of the magnetic field in such complex area is very difficult.

The aim of our study is the development of a measurement method for the determination of the tensor of magnetic fluids permeability $\bar{\mu}$. The fundamental task is the determination of permeability μ of the magnetic fluids oriented in the direction S under the influence of the magnetic field intensity H when vectors H and S are general. In many practical applications of magnetic liquids are these vectors colinear [1, 2]. This contribution focuses on the investigation of permeability in such configurations.

Results of measurements have shown that magnetic nonlinearity of magnetic fluids (thus change of μ in dependence on H) manifests not until relatively high values of magnetic induction, $B > 0.5$ T. This thesis is thus restricted to the measurement of the permeability of magnetic fluids in the linear part of their magnetization characteristics.

Principles of measurement approach

It is necessary to arrange the measurement device in a way that the magnetic fluid sample is magnetized by a homogenous magnetic field. From the theory of electromagnetic field, e.g. [4], it is known that the induction of a toroidal coil is

$$(2) \quad L = \mu F(N^2, \text{dimensions}),$$

where $\mu = \mu_0 \mu_r$ and function F depend on the square of the number N of turns and on geometrical dimensions of the coil and the fluid sample. If the induction of the coil without filling the core with the magnetic fluid is L_0 and the measured induction with the magnetic fluid is L_x , the relative permeability of the magnetic fluid is

$$(3) \quad \mu_r = \frac{L_x}{L_0}.$$

The next step is to determine the induction of the coil with and without the magnetic fluid in its core. Several methods of induction measurement already exist, see, e.g. [3]. If a sample of magnetic fluid with known permeability is available, it can be used for the calibration of the measurement as well.

Possible measurement configurations

Several possible measurement configurations for measuring the inductance of a coil powered with a current were considered and numerically simulated in order to determine the most suitable one. Because of the low relative permeabilities of magnetic fluids ($\mu_r = 1 \sim 5$) the magnetic flux inclines not to pass through the fluid, but to pass through the air or through the container as well. In this point of view, the ideal configuration means that the whole magnetic flux encloses through the ferrofluid. A fictitious ferrofluid with linear relative permeability $\mu_r = 2$ was used for the FEM simulations, magnetic fluids with higher permeabilities would generate even less leakage flux.

Toroidal shape of the measured fluid sample

A hollow toroidal shaped container is filled with measured magnetic fluid. A coil is wired on the torus, and the goal is to find its induction by measurement. The coils must be wound evenly in order to get a homogenous magnetic field. Magnetic flux is then enclosed only through the measured fluid and through the walls of its container (see Fig. 1. for details). The permeability of the container affects the resultant induction and is a source of errors. Because of this, the thinnest possible container walls are required. This configuration has several mostly practical disadvantages, because the maintenance and operation with it is difficult. If we want to fill the torus with a fluid, an opening is necessary and it disrupts needs even winding. As most of magnetic fluids use oil as a carrier liquid, dismantling the device could be required for its cleaning before refilling it with another type of measured fluid.

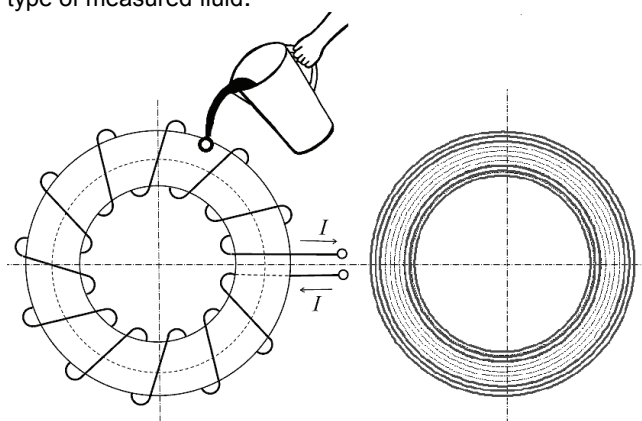

Fig. 1. Measurement configuration with toroidal shaped fluid sample and results of its 2D numerical simulations in planar coordinates featuring magnetic lines of force

Cylindrical shape of measured fluid sample

A hollow glass cylindrical container is filled with measured magnetic fluid. A long coil is evenly wound around the container. The induction of the resultant coil is compared to the coil without the fluid. As we can see in Fig. 2, magnetic flux encloses not only through the magnetic fluid, but through the walls of the container as well and may enclose through ferromagnetic materials present outside the test tube with the measured fluid. Permeabilities of these materials would influence the results of measurement. Large area with absence of any ferromagnetic objects would be needed for such measurement configuration. On the other hand, as the maintenance and cleaning of this configuration is much easier than in the previous configuration, a special container for every measured fluid or cleaning of the container between single measurements is possible.

A coil probe submerged in the magnetic fluid

A small solenoid is chosen as a probe and immersed into the magnetic fluid. If the fluid container is large enough, the magnetic flux generated by the solenoid encloses only through the fluid present and through the winding of the solenoid itself, see Fig. 3.

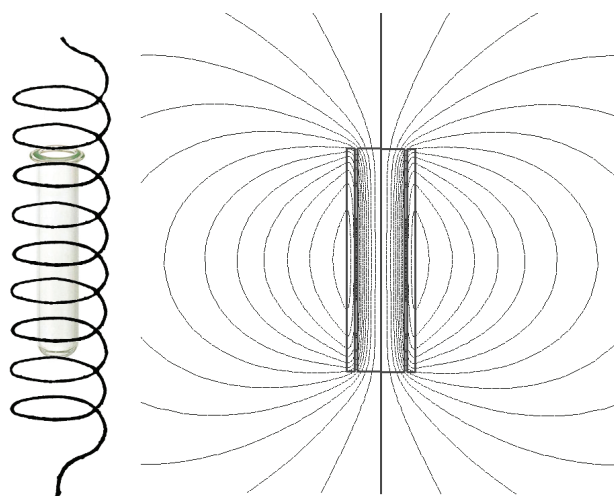

Fig. 2. Cylindrical measurement configuration and its numerical simulation in axisymmetric coordinate system featuring magnetic lines of force

In such a configuration, only the magnetic fluid and material of the solenoid influences the resultant induction. The solenoid should be made of a thinnest wire possible, preferably of a diamagnetic material (e.g. copper) for minimizing the error.

However, this configuration has its practical advantages, as submerging and removing the probe is quick, and the maintenance and cleaning is very simple. Because of this, the configuration is highly recommended for practical use.

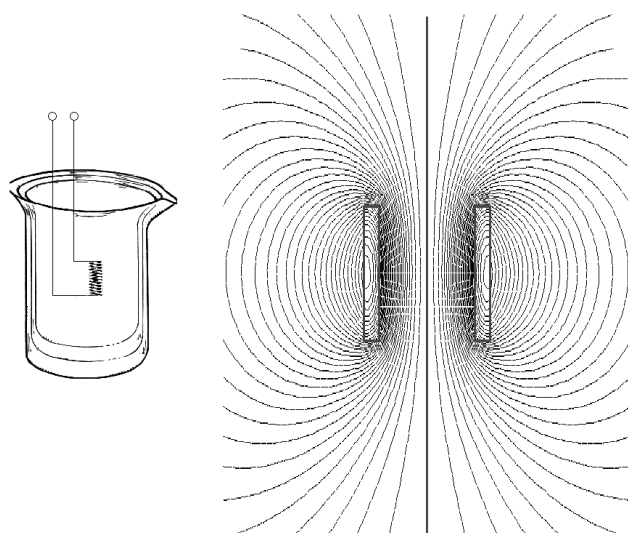

Fig. 3. Coil probe submerged in the measured liquid configuration and its numerical simulation in axisymmetric coordinate system featuring magnetic lines of force

Determining the resulting induction with the use of an RLC bridge

Several methods for measuring the induction of a coil are commonly known, and the most common methods feature the use of an RLC measurement bridge. For a balanced bridge, the measured coil is practically without current. Now the initial permeability

$$(4) \quad \mu_{r0} = \lim_{H \rightarrow 0} \frac{B}{H}$$

is measured. The shape of the $B-H$ characteristics of magnetic fluids is different from the characteristics of other ferromagnetic materials, because the initial permeability is very similar to the permeability in the linear part of the curve. In order to get permeability for higher values of H , measured sample should be magnetized from external source during the measurement.

Use of the approach for a quick operative industrial measurement

Configuration with the measurement solenoid probe submerged into the container filled with measured magnetic liquid was chosen. For determining the resultant inductions, Agilent RLC bridge 6243B was used in our case. The range of measure voltages of this bridge was not enough to capture the nonlinearity of the relative permeability for the higher values of the magnetic field caused by the saturation of the ferromagnetic particles. But as most practical applications of ferrofluids are designed to work in the linear part of the $B-H$ characteristics, this is enough for an operative measurement. This method should allow us capturing these nonlinearities using different bridge or larger coil probe. However, such arrangements would need greater samples of measured fluid. Our measurement details can be seen in Fig. 4 and 5. We used harmonic voltage with amplitude 100mV and the frequency was 100 kHz.

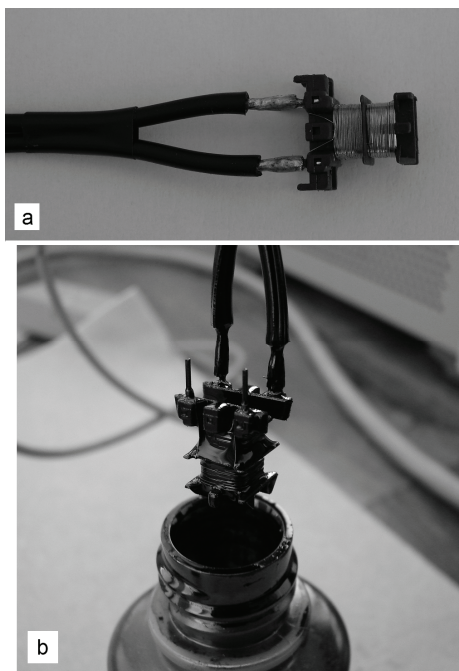

Fig. 4. Quick operative permeability measurement: a – solenoid coil probe; b – probe being submerged into the fluid

Initial permeabilities of several ferrofluids (all of them manufactured by the Ferrotec Company) available at our department were measured and the results can be seen in Table 1.

Even very low values of relative permeability of ferrofluids $\mu_r < 1.2$ can be measured using the proposed method.



Fig. 5. Quick operative permeability measurement arrangement with the RLC bridge

Table 1. Colinear component of permeabilities of certain ferrofluid samples

Ferrofluid sample	Relative permeability μ_r [-]
EMG1111	1,14
EMG607	1,21
EFH1	1,799
EMG707	2,03

Conclusion

A method for measuring key component of permeability of fluids was presented. Knowledge of this component of permeability is crucial in most applications using magnetic fluids. This method can be used for any fluids, even for ferrofluids with very low permeabilities. A simplified quick but less accurate method suitable for industrial utilization is presented as well. Permeability measurement for different values of magnetization, temperature and frequency influences are worth further investigations representing our further research in this field, will be aimed at the investigation of the complete tensor of magnetic fluid permeability.

This work has been supported from the grant project of the University of West Bohemia SGS-2012-039.

REFERENCES

- [1] RAJ, K., MOSKOWITZ, R.: Commercial applications of ferrofluids, *Journal of Magnetism and Magnetic Materials*, 1990, pp. 233-245.
- [2] MAYER D.: Ferrofluids and their applications : *Elektro*. ISSN 1210-0889. Y. 17, n. 3 (2007), p. 78-79 (in Czech).
- [3] BAKSHI, K.A.; BAKSHI, A.V.; BAKSHI, U.A. *Electrical Measurements & Measuring Instruments*. Technical Publications, 2007. 506 s. ISBN 8184312555.
- [4] MAYER, D.: *Applied Electromagnetism (In Czech)*, Kopp, 2012, ISBN 978-80-7232-424-8
- [5] DOLEŽEL, I.; KARBAN, P.; ŠOLÍN, P. *Integral methods in low-frequency electromagnetics*. Hoboken : John Wiley & Sons, 2009. 388 s. ISBN 978-0-470-19550-5.
- [6] ODENBACH, S.: *Ferrofluids - Magnetically Controlled Suspensions, Colloids and Surfaces A: Physicochemical and Engineering Aspects*, 2003, pp. 171–178.

Authors: Prof. Ing. Daniel Mayer, DrSc., University of West Bohemia in Pilsen, Univerzitní 8, 306 14 Pilsen, Czech Republic, E-mail: mayer@kte.zcu.cz, Ing. Petr Polcar, University of West Bohemia in Pilsen, Univerzitní 8, 306 14 Pilsen, Czech Republic, E-mail: paladin@kte.zcu.cz.