

## An Improved Power Quality Monitor Placement Method Using MVR Model and Combine $C_p$ and $R_p$ Statistical Indices

**Abstract.** Power Quality Monitors (PQM) are required to be installed at many buses in a power network in order to assess disturbances such as voltage sags. However, installation of PQMs at all buses considered in the system is uneconomical. This paper presents an improved algorithm to PQM placement using the Multivariable Regression (MVR) model and the  $C_p$  and  $R_p$  statistics. The IEEE 30 bus test system is used to illustrate the effectiveness of the proposed MVR method and compared with the covering and packing, and the monitor reach area based methods.

**Streszczenie.** W artykule zaprezentowano ulepszony algorytm określania współczynnika jakości energii PQM przy wykorzystaniu modelu wielowariacyjnej regresji WVR i statystyki  $C_o$  i  $R_p$ . System zbadano na magistrali IEEE 30. (Metoda badania jakości energii wykorzystująca model MVR i statystykę  $C_p$  i  $R_p$ )

**Keywords:** Power Quality Monitor Placement, Multivariable Regression,  $C_p$  statistic index,  $R_p$  index.

**Słowa kluczowe:** Jakość energii, statystyka  $C_p$

### Introduction

The significant economic losses associated with industrial equipment failures have raised concerns over voltage sags by power utilities and their customers. Voltage sag, also known as voltage dip, is defined as a sudden reduction on the rms voltage, which have been considered as one of the most common power quality disturbances that cause sensitive equipment to malfunction and process interruption [1]. Voltage sags may happen due to short circuit faults and large motor starting in power systems [2]. Information about the actual cause and source of voltage sag is also important to power engineers to help them in making decision to resume back operation [3]. One of the main steps in obtaining information about voltage sag disturbances is to implement power quality monitoring in the power supply networks. Ideally, the whole power system should be monitored by placing power quality monitor (PQM) at each bus and then integrating the entire monitors through a communication facility. However, such a method is not cost effective and not economically justifiable due to a huge amount of redundant data. Therefore, there is a need to develop methods for selecting the number and location of the monitored sites so that the number of monitors is minimized without missing any optimum essential voltage sag information so that the cost of monitoring can be reduced.

In recent years, several studies have been presented to solve the PQM placement problem, by determining the optimal number and location of PQMs. A primary requisite in selecting location of monitors is that it must guarantee observability of the entire system and must ensure that any of the voltage sag event is captured by at least one PQM. A few optimizations techniques have been applied for determining the optimal number and location of PQMs in power systems. In [3], the covering and packing (C&P) method was developed for determining the optimum number and location of PQMs, is based on minimizing the cost of PQMs using the integer linear programming technique. A monitor positioning algorithm was selected to determine the optimal number and location of PQMs for a given distribution system [4]. In this algorithm, the graph theory is applied and system topology is considered to form the coverage matrix. Furthermore, a new concept known as the monitor reach area (MRA) is introduced for optimal location of PQMs [5]. The MRA is defined as the area of the network that can be observed from a given monitor position. In [6], integer programming and fuzzy logic have been applied for determining the optimal placement of PQMs in a

large transmission network for assessing voltage sags. Another optimal PQM placement method considers the use of severity index, MRA matrix and genetic algorithm [7].

From the literature, it is found that most of the existing optimal PQM placement methods consider various assumptions and constraints in the optimization problem formulations. For instance, the approach based on the MRA [5] considers limited number of fault positions and assumes only occurrence of single line to ground fault type, thus cannot ensure complete observability of voltage sags in a distribution system. There is also a limitation in the C & P method [3] which uses Kirchhoff's current law and Ohm's law to get the whole picture of the system's connectivity in order to evaluate the observability of monitors in the system. So, the constraints of the optimization problem formulation in the C&P method are based on steady state information instead of the actual voltage sag information. As for the genetic algorithm based PQM placement method [7], it seems that genetic algorithm is the preferred optimization technique but the disadvantage of genetic algorithm is that it is slow in terms of convergence rate. Therefore, accurate methods are still required for performing optimal PQM placement so as to increase the degree of sensitivity and confidence in the existing methods. A relatively new PQM placement method has been proposed in [9] using the multivariable regression (MVR) model and the  $C_p$  statistical index. In this MVR method, initially, the voltage sag sensitive buses are identified using the correlation coefficients which give the relationship between buses during voltage sags. The voltages of the sensitive buses are then treated as independent variables in the MVR model [8] so as to estimate the other bus voltages. The optimal number and location of PQMs are determined based on the lowest value of the  $C_p$  statistical index. The objective of this paper is to improve the PQM placement method based on the MVR and the  $C_p$  statistical index [9]. To verify the accuracy of the proposed method a comparison between the previous optimal PQM placement methods, namely, the C&P method [3] and the MRA method is made [5]. These methods are tested on the IEEE 30 bus test system.

### MVR and Statistical Indices

The MVR method is based on multivariable regression model [8,9], which is used to estimate the unmonitored bus voltages from the data obtained by the monitored buses where PQMs are to be placed. To determine the appropriate places to install PQMs, the MVR model and  $C_p$

and  $R_p$  statistical indices are introduced and described as follows:

#### Multivariable Regression Model

The MVR model is based on one of the statistical techniques used in applied sciences. It finds a set of partial regression coefficients,  $B_j$  from the dependent variable,  $Y$  which is estimated from a linear combination of the  $k$  independent variables,  $x$ . As a result, a predicted value, denoted by  $\hat{Y}$  dependent variable is obtained as:

$$(1) \quad Y = B_0 + B_1x_1 + B_2x_2 + \dots + B_kx_k + \varepsilon$$

where,  $B_j$  ( $j = 0, 1, 2, \dots, k$ ) are the unknown parameters of regression coefficients and  $\varepsilon$  is a random error. For  $n$  number observations, equation (1) can be written in matrix form as:

$$(2) \quad Y = XB + \varepsilon$$

in which,

$$\varepsilon = \begin{bmatrix} \varepsilon_1 \\ \varepsilon_2 \\ \vdots \\ \varepsilon_n \end{bmatrix}, \quad B = \begin{bmatrix} B_0 \\ B_1 \\ \vdots \\ B_k \end{bmatrix}, \quad Y = \begin{bmatrix} Y_1 \\ Y_2 \\ \vdots \\ Y_n \end{bmatrix},$$

$$X = \begin{bmatrix} 1 & x_{11} & x_{12} & \dots & x_{1k} \\ 1 & x_{21} & x_{22} & \dots & x_{2k} \\ \vdots & \vdots & \vdots & \dots & \vdots \\ 1 & x_{n1} & x_{n2} & \dots & x_{nk} \end{bmatrix}$$

where  $Y$  is a  $(n \times 1)$  vector for observation,  $X$  is a  $(n \times p)$  matrix corresponding to  $p$  number of independent variables,  $B$  is a  $(p \times 1)$  vector of regression coefficients, and  $\varepsilon$  is a  $(n \times 1)$  vector for random errors.

The best estimation of  $B$  can be considered as the one which minimizes the sum of the squared errors. So,  $b$  is written as,

$$(3) \quad b = (X'X)^{-1} X'Y$$

The estimated regression model now becomes,

$$(4) \quad \tilde{Y}_i = b_0 + \sum_{j=1}^k b_j x_{ij}, \quad i = 1, 2, \dots, n$$

The difference between the observed ( $Y_i$ ) and estimated ( $\tilde{Y}_i$ ) variables is the error that is given by [11],

$$(5) \quad E = Y_i - \tilde{Y}_i$$

From the MVR model, the unmonitored bus voltages are estimated using the data obtained from the monitored buses where PQM are to be placed. In order to obtain the most appropriate places to install and monitor bus voltages, some statistical indices are introduced and used.

#### Correlation Coefficient

The correlation coefficient (CC) is a statistical index which gives the relationship between two data sets with variables,  $x$  and  $y$ . The CC can be calculated as:

$$(6) \quad R_{x,y} = \frac{\text{cov}(x,y)}{\delta_x \delta_y}$$

where,  $R_{x,y}$  is the CC,  $\text{cov}(x,y)$  is the covariance,  $x, y$  and  $\delta_x$  and  $\delta_y$  are the standard deviations of  $x$  and  $y$ , respectively.

In this study, the CC shows the relationship between buses during voltage sags, which in turn gives an idea about the sensitivity of buses during voltage sags. At least two buses with maximum and minimum CC values are selected from the  $N$  buses.

#### $C_p$ Statistic

The  $C_p$  statistic is a criterion for the total mean square error (MSE) of the regression model. The model with the lowest  $C_p$  value is considered as the most adequate model [10]. The  $C_p$  statistic is given by:

$$(7) \quad C_p = (SSE(p) / MSE(p)) - n + 2p$$

where  $SSE(p)$  is the residual sum of square error for the model with  $p-1$  variables and is given by:

$$(8) \quad SSE = \sum_{i=1}^n (Y_i - \hat{Y}_i)^2$$

and  $MSE(p)$  is the residual MSE when all the available variables are used and is expressed as,

$$(9) \quad MSE(p) = SSE(p) / (n - p) = \sum_{i=1}^k (Y_i - \hat{Y}_i)^2 / (n - p)$$

where  $n$  is the number of observations and  $p$  is the number of variables used for the model plus one.

#### Coefficient of multiple determination ( $R_p$ )

The  $R_p$  statistic is a criterion for evaluation of dependent variable value when the independent variables  $x_1, x_2, \dots, x_k$  are used. This coefficient is given as follows.

$$(10) \quad R_p = (SSR / S_{yy}) = 1 - (SSE / S_{yy})$$

where,  $SSR$  is the regression sum of square,  $S_{yy}$  is the total sum of square and  $SSE$  is the sum of square error. The  $R_p$  is between zero and one, that it is one the normality criterion for evaluation and comparison of various regression models.

#### New Algorithm for Determining the Optimal Number and Location of PQM

In this study, it is assumed that the maximum number of PQMs is fixed, such that not more than  $m$  numbers of PQMs are installed at the  $N$  buses. It is suggested to use a list of all possible PQM locations, indexed by a decision variable ( $P_{Loc.}$ ) which is given by:

$$(11) \quad 1 \leq P_{Loc.} \leq 2^m - 1$$

where  $P_{Loc.}$  is the location index representing the repartition of  $m$  PQMs through the  $N$  buses.

The new algorithm for determining the optimal number and location of PQMs is shown in Figure 1.

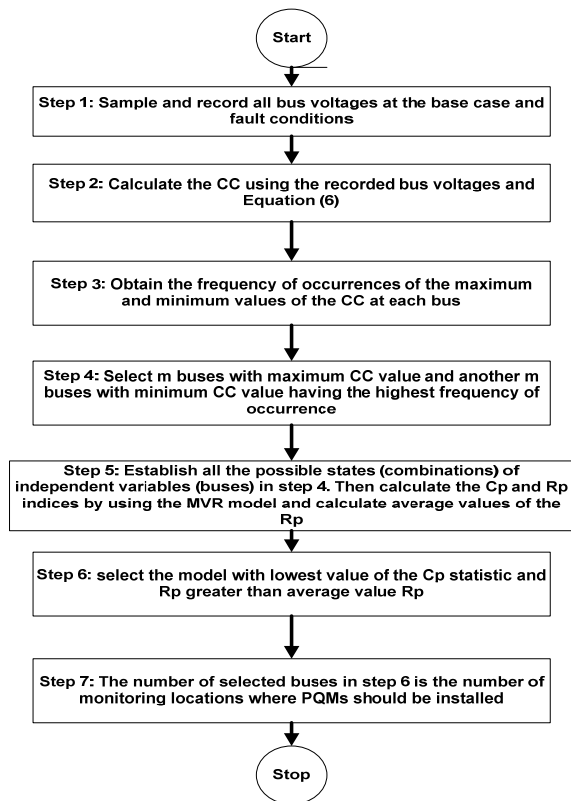

Fig.1. The proposed algorithm for PQM placement

### Test Results

The IEEE 30 bus test system shown in Figure 2 is used to validate the MVR PQM placement method using the MVR model and the  $C_p$  and  $R_p$  statistics. In the IEEE 30 bus test system, bus 1 is the slack bus, bus 2 is the voltage controlled bus, buses 5, 8, 11 and 13 are installed with synchronous condenser and the remaining buses are the 24 load buses. This test system has three different voltage levels, that is, buses 11 and 13 at 11 kV, buses 1 to 9 and 28 at 132 kV, and the remaining buses are at 33 kV. The placement of PQMs is verified by performing power flow simulations using the DlgSILENT Power Factory 14.0.524 and calculating all the statistical indices using the MATLAB software.

### Results of the MVR method

In the simulation for determining the placement of PQMs, several short circuit tests with fault resistance between 1.2 to 0.2 ohm (LG, LLG and LLL) are required to determine the relationship between the unmonitored or estimated bus voltages and the monitored or observed bus voltages. For the placement of PQMs, the CC of all buses in the IEEE 30 bus test system is calculated by using (6). Then, the two buses that have the maximum relationship and the two buses with minimum CC are selected for each simulated fault. The frequency of occurrence of maximum and minimum CC values during all the fault tests for each bus are shown indicated in Table 1. From the Table, the buses 9, 25, 26 and 27 are considered to have high frequency of occurrence for maximum CC values and buses 1, 5 and 12 have high frequency occurrence from the minimum CC values.

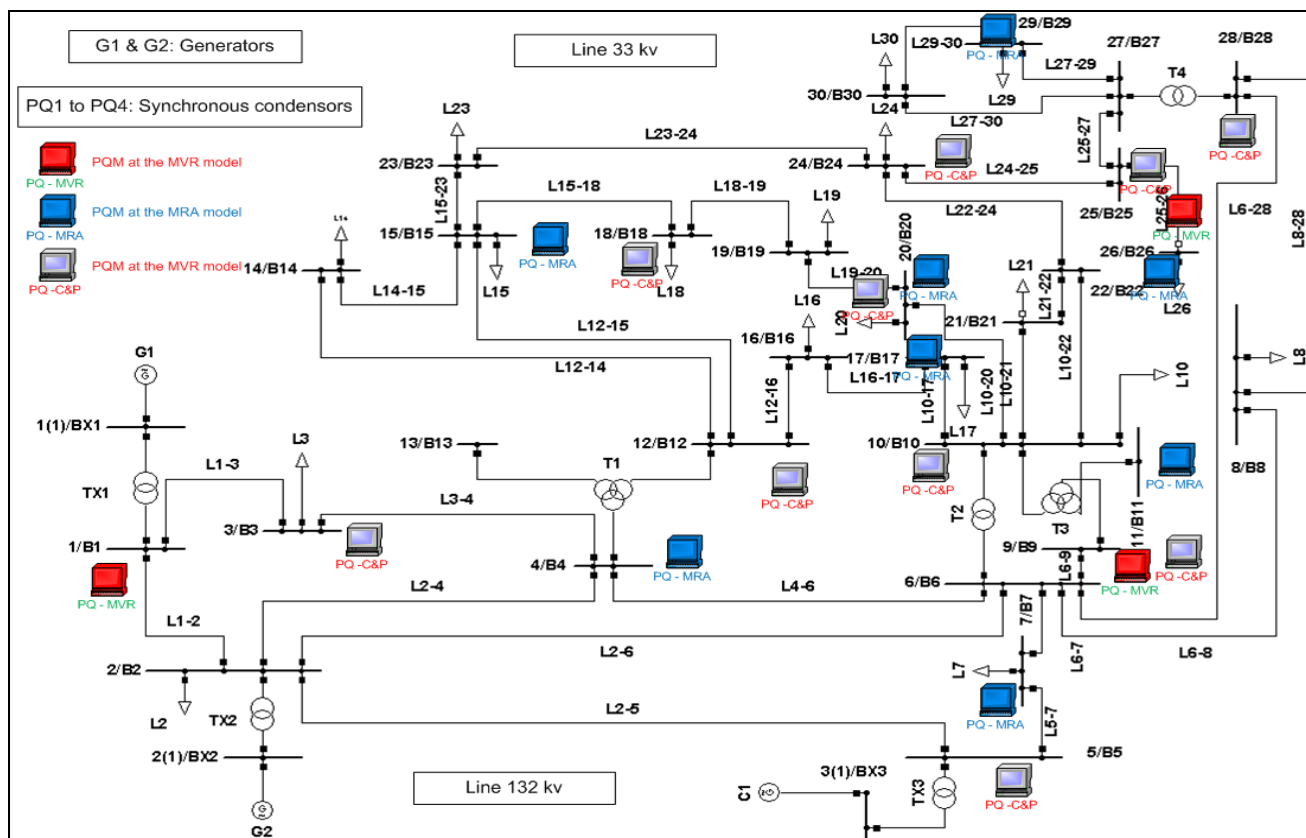

Fig.2. One-line diagram of the IEEE 30 bus test system

In accordance to the algorithm described, all the possible states with 2, 3, 4, 5, and 6 independent variables are established and then the  $C_p$  and the  $R_p$  statistics are calculated using the MVR model as shown in Table 1.

Table 1. The frequency of the CC maximum and minimum values during faults

Bus	Max.	Min.	Bus	Max.	Min.
1	1	19	17	1	0
2	2	0	18	1	0
3	3	0	19	3	0
4	1	0	20	2	0
5	1	19	21	3	0
6	2	0	22	3	0
7	1	0	23	0	0
8	2	0	24	1	0
9	5	0	25	4	0
10	1	1	26	4	0
12	0	9	27	5	0
14	1	8	28	2	0
15	1	0	29	3	0
16	0	0	30	3	0

In each of the above combination of independent variable, the model with the lowest value of the  $C_p$  and the suitable value of the  $R_p$  is selected as shown in Table 2. The model with lowest value of the  $C_p$  statistic and  $R_p$  value greater than average value as showed in Table 2 are selected for PQM placement. So, from the Table 2, the  $C_p$  and the  $R_p$  with 3.03 and 0.9985 values respectively has identified as the three PQMs to be installed at buses of 1, 9 and 26.

Table 2. The results of various MVR models with different independent variables a fault occurs at bus 18

Independent variables in state	Suitable variables	Rp	Cp
X1,X5,X9,X27, X12, X25	X1,X5,X9,X27, X12, X25	0.9999	7
X1,X5,X9,X27, X12	X1,X9,X27, X12	0.9980	5.57
X1,X5,X9,X26	<b>X1,X9,X26</b>	<b>0.9985</b>	<b>3.03</b>
X5,X12,X27	X5,X27	0.9968	2.02
X12,X27	X27	0.9914	0.37
The Rp average		<b>0.9969</b>	

To further validate the result, various types of faults have been randomly simulated in the system at various locations and then the RMS voltage magnitudes are measured at the selected monitored buses, namely at bus 1(PQM1), 9 (PQM2) and 26(PQM3) as shown in Figure. 2. Figure. 3 shows the measured RMS voltage magnitudes for several faults simulated with fault resistance 0.01 in the IEEE 30 bus system. As shown in Fig. 3, all the faults have triggered the monitors at buses 1 (PQM1) , 9 (PQM2) and 26 (PQM3), because the phase voltage magnitudes in each plot has dropped below the voltage threshold level,  $t \leq 0.9$  p.u which is the usual trigger voltage level of PQM monitors for voltage sag recording. Thus, the placement of monitor at buses 1 (PQM1), 9 (PQM2) and 26 (PQM3) in the IEEE 30 bus system has been proven to be suitable to completely monitor voltage sag events in the whole system.

*Comparison of PQM placement methods in terms of number of PQM*

The MVR, the C&P [3] and the MRA [5] methods are applied to the IEEE 30 bus test system in the optimum number of monitors are found to be three, ten and eight PQMs for the MVR, C&P and the MRA methods respectively. Table 3 shows a comparison of the placement using the various methods. It is noted from Table 3 that the proposed method PQM results is better than the C&P and

MRA methods in terms of the Total Cost Saving (TCS) percentage which is calculated using,

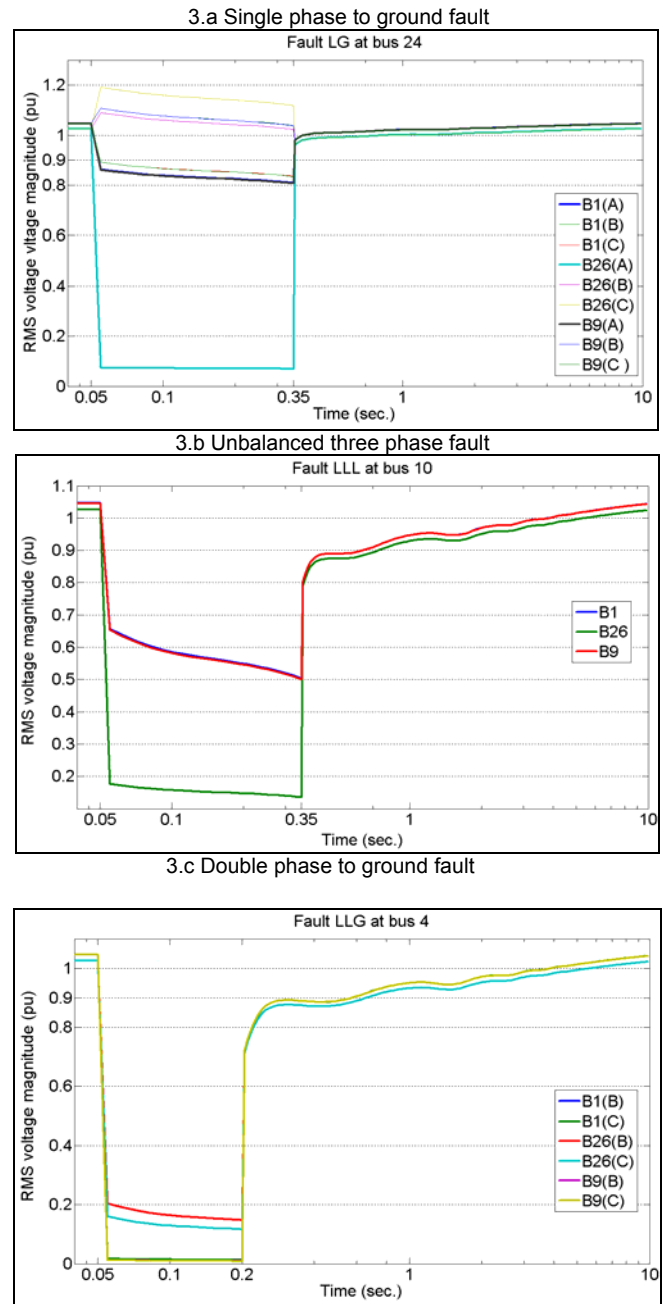

Fig.3. RMS voltage waveforms recorded by the PQMs according to the MVR method

$$(12) \quad TCS\% = \left(1 - \frac{N}{m}\right) * 100$$

where N is the number of PQMs installed the test system.

For instance, according to (12) and if each PQM has equal cost and monitor voltage threshold sensitivity of 0.6 p.u., the calculated TCS percentage values are 90%, 73.4% and 66.7% for the MVR, MRA and C&P methods, respectively. These values imply that the MVR, the MRA and the C&P methods can scan the RMS voltage magnitude with 3, 8 and 10 PQMs, thus reducing the cost of PQMs by 90, 73.4 and 66 percent, respectively.

Table 3. Number and location of PQM obtained by the MVR, MRA and C&P with voltage threshold 0.6 pu

Bus	MVR	MRA	C&P
1	PQM1	-	-
2	-	-	-
3	-	-	PQM1
4	-	PQM1	-
5	-	-	PQM2
6	-	-	-
7	-	PQM2	-
8	-	-	-
9	PQM2	-	PQM3
10	-	-	PQM4
11	-	PQM3	-
12	-	-	PQM5
13	-	-	-
14	-	-	-
15	-	PQM4	-
16	-	-	-
17	-	PQM5	-
18	-	-	PQM6
19	-	-	-
20	-	PQM6	PQM7
21	-	-	-
22	-	-	-
23	-	-	-
24	-	-	PQM8
25	-	-	PQM9
26	PQM3	PQM7	-
27	-	-	-
28	-	-	PQM10
29	-	PQM8	-
30	-	-	-
No. bus	3	8	10
TCS%	90%	73.4%	66.7%

Table 4 shows the number of PQMs determined by the MVR, the MRA and C&P methods for the threshold voltage 0.6 to 0.8 pu., Figure. 4 shows the percentage of TCS and the number of PQM obtained by the three methods. however, it showing that the MVR method has the highest TCS% and is minimum number of PQM.

Table 4. Number of PQM to the MVR, the MRA and C&P methods for the threshold voltage 0.6, 0.7 and 0.8 pu.

Threshold voltage	MVR	MRA	C&P
	Number of PQM		
0.6	3	8	10
0.7	3	6	10
0.8	3	3	10

### Conclusion

This paper presents an improved algorithm to PQM placement using the MVR model and the  $C_p$  and  $R_p$  statistics. The MVR, MRA and C&P methods are tested on the IEEE 30 bus test system for the purpose of comparison. The test results showed that the MVR method requires only three PQMs to monitor the whole system even the monitor sag triggering voltage is set to 0.6 p.u. Therefore, it is proven that the MVR method can save approximately 90% of total cost of monitor installation whereas the MRA method with eight monitors can save 73.4% while the C&P method with ten monitors can save 66.6%.

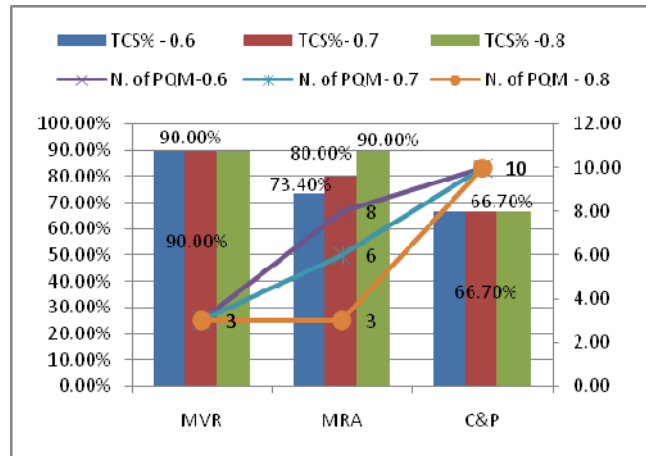

Fig.4. Comparison of TCS% and number of PQM obtained by the MVR, the MRA and the C&P methods

### REFERENCES

- [1] Xuemeng Y., Yonghai X., Danyue L., Analysis and Calculation on Indices of Voltage Sag, Proceeding of Power and Energy Engineering Conference, (2009), 1-5
- [2] Ghosh A., Lubkeman D., The Classification of Power System Disturbance Waveforms Using a Neural Network Approach, IEEE Transactions on Power Delivery, 10 (1995), 109-115
- [3] Eldery M A., El-saadany E F., Salama M V A., A Novel Power Quality Monitoring Allocation Algorithm, IEEE Transactions on Power Delivery, 21, (2006), 768-777
- [4] Won D., Moon S., Optimal Number and Locations of Power Quality Monitors Considering System Topology, IEEE Transactions on Power Delivery, 23 (2008), 288-295
- [5] Olguin G., Bollen M., Optimal Dips Monitoring Program for Characterization of Transmission System, IEEE Power Engineering Society General Meeting, (2003), 2484-2490
- [6] Haghbin M., Farjah E., Optimal Placement of Monitors in Transmission Systems Using Fuzzy Boundaries for Voltage Sag Assessment, IEEE Conference on Power Tech, (2009), 1-6
- [7] Ibrahim A., Mohamed A., Shareef H., Optimal Placement of Voltage Sag Monitors Based on Monitor Reach Area and Sag Severity Index, IEEE Student Conference on Research and Development, (2010), 467-470
- [8] Kazemi A., Mohamed A., Shareef H., A New Method for Determining Voltage Sag Source Locations by Using Multivariable Regression Coefficients, Journal of Applied Sciences, 11 (2011), 2734-2743
- [9] Kazemi A., Mohamed A., Shareef H., A New Power Quality Monitor Placement Method Using the Multivariable Regression Model and Statistical Indices, International Review of Electrical Engineering, 6 (2011), 2530-2536
- [10] Mallows C., Some Comments on  $C_p$ , Technometrics, 15 (1973), 661-675
- [11] Kuzjurin N., Combinatorial Problem of Packing and Covering and Related Problem of Integer Linear Programming, Journal of Mathematical sciences, 108 (2002), 1-48

### Authors:

- 1-Asadollah Kazemi, Ph.D student, Email: [asadollahk@yahoo.com](mailto:asadollahk@yahoo.com);
- 2-Professor Dr. Azah Mohamed, Email: [azah@eng.ukm.my](mailto:azah@eng.ukm.my);
- 3-Dr. Hussain Shareef, Email: [hussain\\_in@yahoo.com](mailto:hussain_in@yahoo.com).
- 4-Dr. Hadi Zayandehroodi, Email: [h.zayandehroodi@yahoo.com](mailto:h.zayandehroodi@yahoo.com)  
Department of Electrical, Electronic and Systems Engineering, Universiti Kebangsaan Malaysia (UKM), Bangi, 43600, Selangor, Malaysia.