

## Comparative study of conventional and matrix converter fed brushless dc motor drive

**Abstract** The conventional DC link converters and matrix converters are used for driving a Brushless DC motor with trapezoidal back electromotive force. This paper deals with design of matrix converter for BLDC motor with the objective of lowering supply current harmonics. A comparative study of conventional DC link converter and three phase matrix converter are presented. It is to be noted that the conventional converters with DC-link requires two stages of conversion, whereas a matrix converter, in a single stage drives a BLDC motor. The proper switching of the matrix converter is designed and presented in this paper. By employing matrix converter, the ac source current becomes nearly sinusoidal and total harmonic distortion gets very much reduced. A matrix converter fed BLDC motor is simulated in MATLAB Simulink and results are shown to validate the harmonic reduction. The hardware implementation of the matrix converter is also discussed in this paper.

**Streszczenie.** W artykule zaprezentowano projekt przekształtnika macierzowego zastosowanego do zasilania silnika bezszczotkowego BLDC. Porównano konwencjonalny przekształtnik DC z przekształtnikiem macierzowym trójfazowym. Przedstawiono wyniki symulacji. (Analiza porównawcza konwencjonalnego i macierzowego przekształtnika w zastosowaniu do zasilania silnika BLDC)

**Keywords:** Matrix converter, Permanent Magnet Brushless DC Motor, DC link converter, Total Harmonic distortion.

**Słowa kluczowe:** przekształtnik macierzowy, silnik bezszczotkowy BLDC

### Introduction

Permanent Magnet Brushless DC motors can be considered as a kind of three phase synchronous motors, having permanent magnets on the rotor, replacing mechanical commutator and brush gear. Permanent Magnet Brushless DC (PMBLDC) Motors are the latest choice of researchers due to their high efficiency, silent operation, compact size, high reliability and low maintenance requirements [1]. The brushless DC motor has a permanent magnet rotor, and stator windings are wound such that the back electromotive force is trapezoidal. It requires rectangular shaped stator phase currents to produce constant torque [2].

Brushless DC motors are traditionally driven by Pulse Width Modulated Voltage Source Inverters (PWM-VSI). However it has certain disadvantages like need of additional filter elements at input and output, the poor quality of output waveforms, harmonics depends on stability of DC link voltage and so on [3]. Compared with these conventional converters matrix converters has the most desirable features-sinusoidal input and output currents, regeneration capability, generation of load voltage with arbitrary amplitude and frequency and so on [4]. Earlier, Matrix converter was employed for driving induction motor and permanent magnet synchronous motors. Many control methods of matrix converters have been proposed which includes AlesinaVenturini (AV) method, Pulse Width Modulation (PWM) method, Space Vector Modulation Technique (SVM) etc [5]-[6]. The various modulation techniques have been analyzed in references [7]-[10]. Matrix converter can also be used to drive Brushless DC motor [12]. A new method of matrix converter driving Brushless DC motor based on indirect equivalent model combining current source rectifier and voltage source inverter connected through a virtual DC link has been demonstrated in reference [11, 14].

This paper focuses on the reduction of source side harmonic ripples. By employing a three phase to three phase matrix converter that drives a BLDC motor, this can be achieved. The switching sequence employed for matrix converter was discussed in detail. A comparative analysis has been made with the conventional DC link converter to show that the proposed system is better than the conventional system. The designed converters were simulated using MATLAB/Simulink and were analyzed.

This paper is organized as follows. Section 2 describes conventional DC link inverter fed BLDC drive. Section 3 presents fundamentals and working of matrix converter. Section 4 describes the switching strategy of conventional DC link inverter and matrix converter fed BLDC drive. The proposed method along with simulation and results are presented in Section 5. Hardware implementation is discussed in section 6. Finally conclusions are summarized and presented in section 7.

### Conventional DC Link Converter

The conventional DC link converter consists of two stages of conversion. The first stage consist of a bridge rectifier, in which, the three phase AC supply is fed to the rectifier so that the rectifier performs the operation of AC to DC conversion. After this conversion, it was fed to the energy storage element which is usually a capacitor. The inverter performs the operation of DC to AC conversion which is provided at the second stage. In this case, the gating pulses to the inverter must be given in such a way that the switches have to be turned ON depending up on the hall sensor signal.

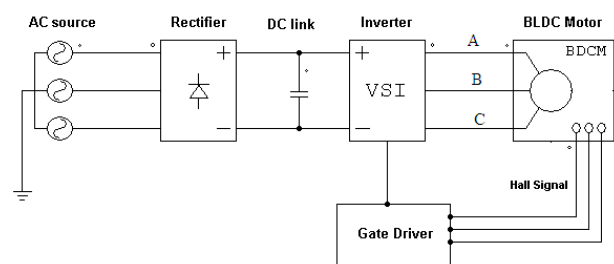

Fig.1 Block diagram of DC link converter driving BLDC motor

But due to the bridge rectifier at the front end, the inverter circuit will draw input currents that are rich in 5<sup>th</sup> and 7<sup>th</sup> harmonics which can become a significant problem because the harmonic distortion injected into the mains cause major power losses. Another problem is that large capacitor is placed across the DC-link to provide a constant DC voltage source with small variation and for energy storage. These capacitors are temperature sensitive and also they will occupy a reasonable volume.

### Three Phase Matrix Converter

A direct AC-to-AC converter commonly termed a matrix converter has a simple structure and many attractive features. The Three phase matrix converter is a single stage converter which has nine bi-directional switches, to connect, directly a three phase voltage source to a three phase load. Fig.2 shows the schematic representation of matrix converter driving a brushless DC motor, where a, b, c are input phases and A, B, C are motor terminals. The input voltage sources are assumed to be three phase balanced voltage sources. The phase relation between load voltages and input voltages can be expressed as follows.

$$\begin{bmatrix} V_A(t) \\ V_B(t) \\ V_C(t) \end{bmatrix} = \begin{bmatrix} S_{Aa}(t) & S_{Ab}(t) & S_{Ac}(t) \\ S_{Ba}(t) & S_{Bb}(t) & S_{Bc}(t) \\ S_{Ca}(t) & S_{Cb}(t) & S_{Cc}(t) \end{bmatrix} \begin{bmatrix} V_a(t) \\ V_b(t) \\ V_c(t) \end{bmatrix}$$

$$V_o = S \times V_i$$

Where, S is the instantaneous switching transfer matrix. The similar relationship is valid for input and output currents.

The motor is supplied by three phase rectangular current blocks of 120° duration, in which ideal motional EMF is trapezoidal. The machine needs rotor position information for every 60° electrical.

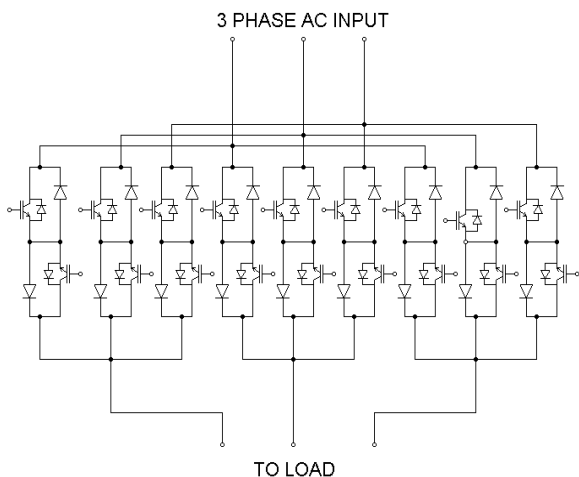

Fig.2 Schematic diagram of a three phase matrix converter

As back EMF is directly proportional to the motor speed and developed torque is almost directly proportional to the phase current, the torque can be maintained constant. The switching strategy presented in this paper employs both the hall signal and magnitude of the input phase voltage so as to drive the BLDC motor.

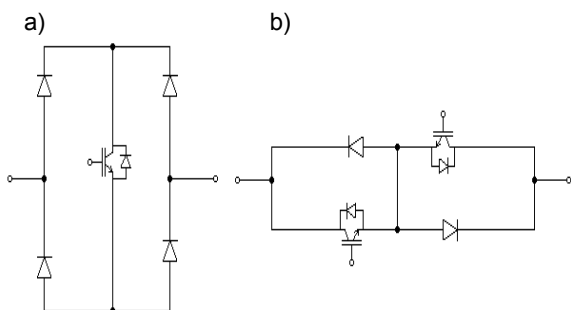

Fig. 3 (a) Diode bridge Cell (b) Common emitter cell

The matrix converter requires a bidirectional switch capable of blocking voltage and conducting current in both the directions. But there are no such switches currently available. Hence, two separate semiconductor switches are used to construct suitable switch cells. There are three types

of switching configuration available. The diode bridge bidirectional switch cell Fig. 3(a) consists of an insulated gate bipolar transistor (IGBT) at the centre of a single diode bridge. The common emitter cell Fig. 3(b) arrangement consists of two diodes and two IGBTs connected in anti parallel. The diodes are included to provide reverse blocking capability. The common collector configuration is also possible.

Among these, common emitter configuration is preferred mostly. The central common connection provides some transient benefits during switching.

### Switching strategy

#### Conventional DC Link Converter

In order to have 120° square wave phase currents, the commutation must be provided to the windings such that two switches are turned ON at a time. The following Table 1 shows the switching sequence formulation based on the rotor position [13].

Table 1. Switching Sequence for DC link converter.

RotorPosition	Phase A	Phase B	Phase C
0-60°	1	0	-1
60°-120°	1	-1	0
120°-180°	0	-1	1
180°-240°	-1	0	1
240°-300°	-1	1	0
300°-360°	0	1	-1

The switching sequence can be explained as follows. In Table I, “1” represents positive excitation, “-1” represents negative excitation and “0” represents no current flow through the winding. For the rotor position 0°-60°, conducting devices are turned ON so that winding C and A gets energized with positive voltage applied to A phase and negative voltage applied to C phase. For the rotor position 60°-120°, conducting devices are turned ON so that winding B and A gets energized. This process continues for a full electrical cycle and various switches conduct for various positions.

### Matrix converter

Matrix converter has a simple structure and many attractive features. Its main advantages are adjustable (including unity) power factor, bi-directional power flow and possibility of a compact design due to the lack of large energy storage elements compared to a conventional AC/DC/AC converter. Furthermore reactive elements on the input and output can be replaced with small AC-filter elements due to low harmonic distortion of waveforms. Matrix converters can regenerate energy back into the mains from the load side, where the mains current is sinusoidal and the displacement factor seen by the mains can be adjusted by proper modulation irrespective of the type of load.

The matrix converter is fed by a three phase voltage source and for this reason; input terminals should never be short circuited. Also, due to inductive nature of the load, the output phases must never be opened. Considering these constraints, the switching function can be defined as follows:

$$S_{kj} = \begin{cases} 1, & \text{closed} & K = \{a, b, c\} \\ 0, & \text{open} & j = \{A, B, C\} \end{cases}$$

With these restrictions, the three phase matrix converter has 27 possible switching states [4, 7].

The switching sequence formulation can be explained as follows: The rotor position of the brushless DC motor was sensed using Hall sensors. For every 60° electrical, output can be obtained from the Hall sensor. Along with the Hall signal obtained, the magnitude of input voltages goes maximum or minimum for every 60°. The maximum,

minimum and median voltage assignment was performed with the help of Table 2[8, 14].

Table 2: Maximum, Minimum and Median voltage Assignment.

Angle (rad)	Max	Med	Min
0- $\pi/6$	$V_{sa}$	$V_{sa}$	$V_{sb}$
$\pi/6$ - $\pi/3$	$V_{sa}$	$V_{sc}$	$V_{sb}$
$\pi/3$ - $\pi/2$	$V_{sa}$	$V_{sc}$	$V_{sb}$
$\pi/2$ - $2\pi/3$	$V_{sa}$	$V_{sb}$	$V_{sc}$
$2\pi/3$ - $5\pi/6$	$V_{sa}$	$V_{sb}$	$V_{sc}$
$5\pi/6$ - $\pi$	$V_{sb}$	$V_{sa}$	$V_{sc}$
$\pi$ - $7\pi/6$	$V_{sb}$	$V_{sa}$	$V_{sc}$
$7\pi/6$ - $4\pi/3$	$V_{sb}$	$V_{sc}$	$V_{sa}$
$4\pi/3$ - $3\pi/2$	$V_{sb}$	$V_{sc}$	$V_{sa}$
$3\pi/2$ - $5\pi/3$	$V_{sc}$	$V_{sb}$	$V_{sa}$
$5\pi/3$ - $11\pi/6$	$V_{sc}$	$V_{sb}$	$V_{sa}$
$11\pi/6$ - $2\pi$	$V_{sc}$	$V_{sa}$	$V_{sb}$

The ideal current flowing through the stator of the brushless DC motor at any instant was known. The three phase current waves conduct for each 120° such that it may be either positive, negative or zero. Depending on the output current and the magnitude of input voltage assignment and the hall signal, a switching pattern was developed.

The transfer matrix has been realized as a function of hall sensor signal (H), maximum of input voltage and minimum of input voltage. Using this realization function, the switch to be turned ON can be identified. Depending on the speed of the motor hall sensor signal (H) changes due to which the switching frequency also varies. The transfer matrix and the switching function can be related as follows:

$$\begin{bmatrix} S_{Aa}(t) & S_{Ab}(t) & S_{Ac}(t) \\ S_{Ba}(t) & S_{Bb}(t) & S_{Bc}(t) \\ S_{Ca}(t) & S_{Cb}(t) & S_{Cc}(t) \end{bmatrix} = F\{H, MAX(v), MIN(v)\}$$

### System modeling and simulation MATLAB Simulation of DC link converter driving BLDC motor

The simulation was performed with the help of MATLAB/Simulink software. Power circuit of converters has been modeled using power electronic Toolbox in Matlab/Simulink. Fig.4 shows the simulink model of conventional DC link converter driving brushless DC motor.

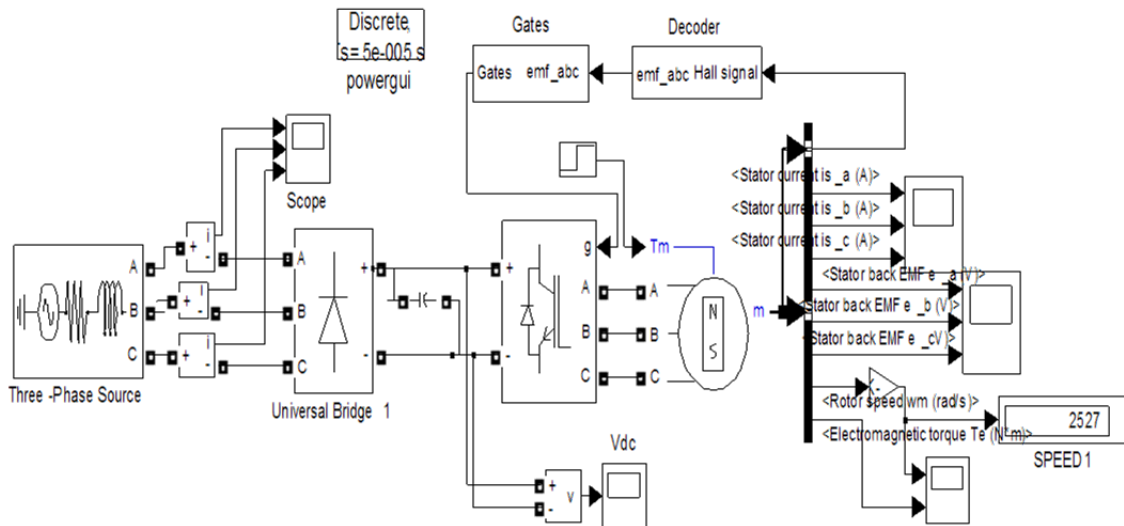

Fig.4 MATLAB Simulink model of DC link converter driving BLDC motor

The Universal Bridge block allows simulation of converters using either naturally commutated (or line-commutated) power electronic devices (diodes or thyristors) or forced-commutated devices (GTO, IGBT, and MOSFET). The gating pulse generation for conventional converter is designed in such a manner that only two devices conduct at a time. The model used in simulation assumes that the winding distribution and flux established by the permanent magnets produce three trapezoidal back EMF waveforms. Also Machine block assumes a linear magnetic circuit with no saturation of the stator and rotor iron.

The DC link converter is fed by a 3phase supply which has line voltage and frequency of 220V and 50Hz, respectively. Based on the signal from the hall sensor signal, the two switches are made to ON at a time which conducts for a period of 120°. This makes the stator current to flow rectangular for a trapezoidal back EMF motor. Simulation results were given in Fig.5(a)-(e).

Fig.5(a) shows the trapezoidal stator back EMF for three phases. Fig.5(b) shows the stator currents of the brushless DC motor for three phases. Fig.5(c) shows the speed and electromagnetic torque variations. Fig.5(d) shows the supply current waveforms for three phases. Fig.5(e) shows the FFT analysis from which it is obvious that supply side current harmonics is found to be around 35%.

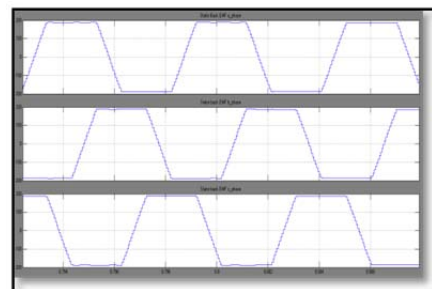

Fig.5 (a) Stator Back EMF



Fig.5 (b) Stator current

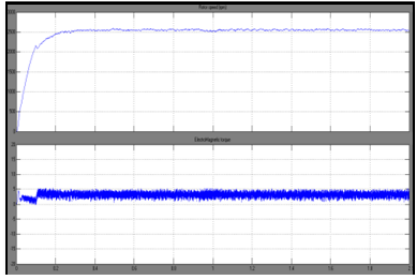

Fig.5 (c) Speed in rpm and Electromagnetic torque

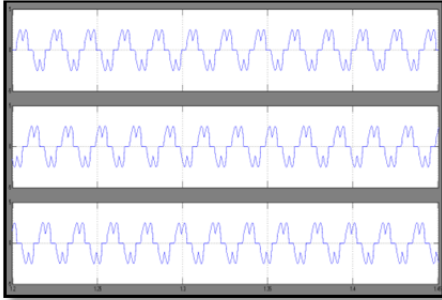

Fig. 5 (d) Supply current

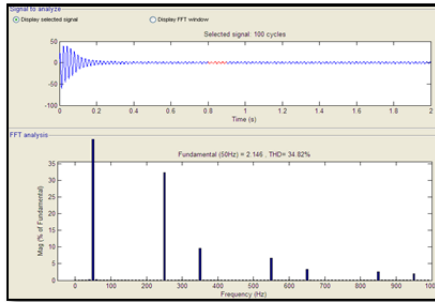

Fig.5 (e) Total Harmonic Distortion Analysis  
Fig. 5 Simulation results for BLDC motor drive with conventional DC link converter

## MATLAB Simulation of matrix converter driving BLDC motor

Fig.6 shows the simulink model of matrix converter driving brushless DC motor. The simulation model consists of three main parts. First part includes the design of matrix converter. The common emitter configuration bi-directional switch cell along with the central common connection was chosen to design a 3×3 matrix converter. The second part consists of switching sequence in which the switches for each output phase is calculated and then the control signals were generated. The last part is the design of input filter for matrix converter.

In this model, based on the switching function realization switches to be turned on for each phase has been calculated and it was implemented using a state flow model. The switches for one output phase connect the related input phases to the output phase. This switching gives the target output wave forms and thus runs the BLDC motor. The input filter for the matrix converter was designed in such a way to reduce the supply current harmonics.

The simulink model given in Fig.6 is used with ideal bidirectional switches. A filter of  $L=40\text{mH}$  and  $C=0.1\mu\text{F}$  is placed at the supply side. The matrix converter is fed by a 3phase supply which has line voltage and frequency of 220V and 50Hz, respectively. BLDC motor having ratings 300V Vdc and 4250 rpm has been used for simulation. Simulation results were given in Fig.7(a)-(f).

Fig.7(a) shows the trapezoidal stator back EMF for three phases. Fig.7(b) shows the stator currents of the brushless DC motor for three phases. Fig.7(c) shows the electromagnetic torque of brushless DC motor. Fig.7(d) shows the speed of the BLDC motor. Fig.7(e) shows the three phases of supply current waveform with an input filter for matrix converter circuit.

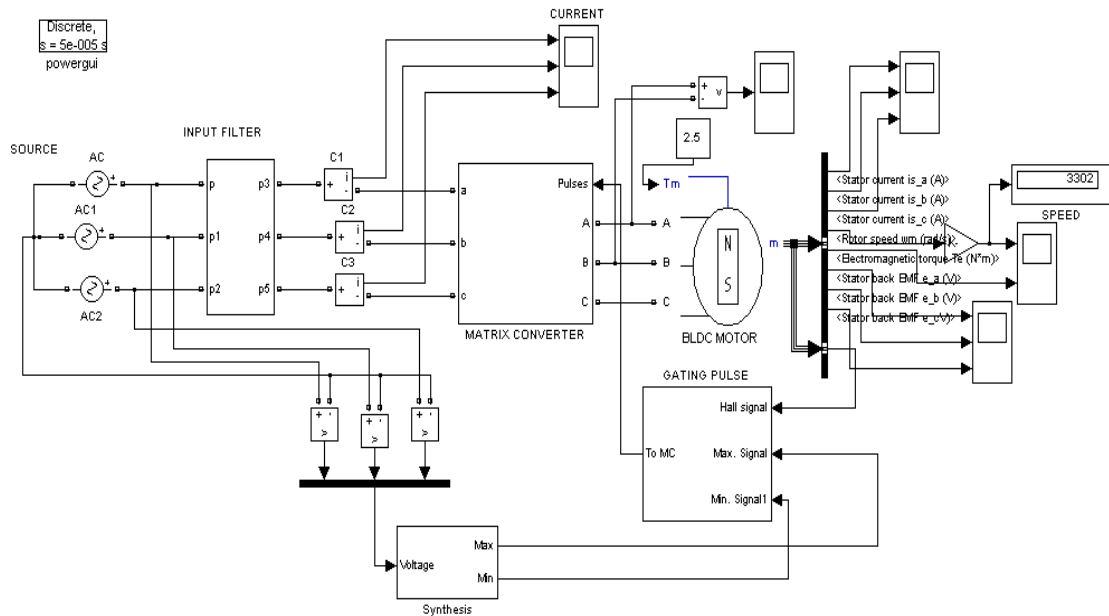

Fig.6 MATLAB simulink model of Matrix Converter driving BLDC motor

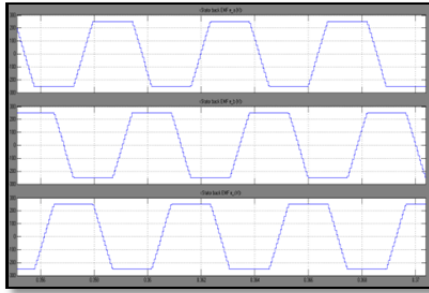

Fig.7 (a) Stator Back EMF

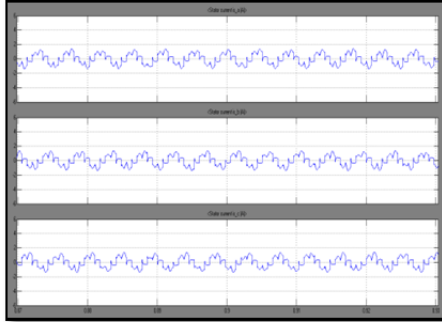

Fig.7 (b) Stator current

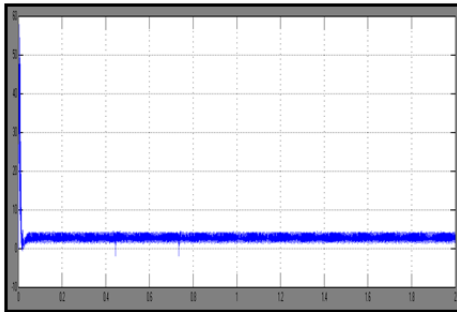

Fig.7 (c) Electromagnetic torque

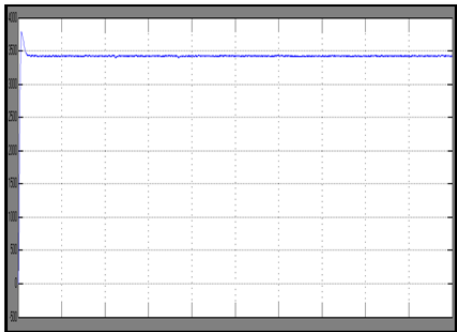

Fig.7 (d) Speed in rpm

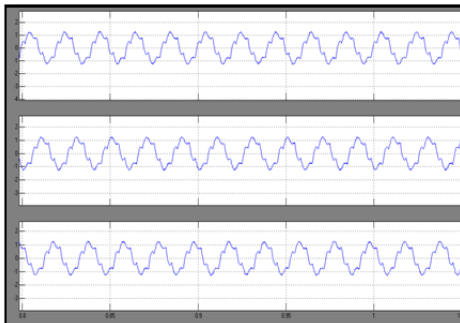

Fig.7 (e) Supply current

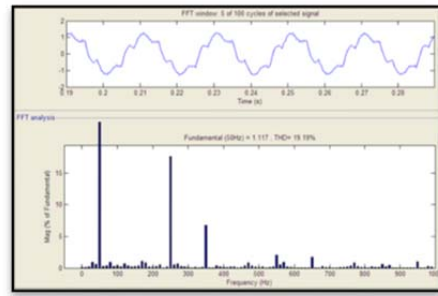

Fig. 7(f): Total Harmonic Distortion Analysis

With filter, the total harmonic distortion has been reduced to 19%. Fig.7 (f) shows the FFT analysis of the proposed circuit.

### Hardware Implementation

The design of the hardware implementation of the proposed matrix converter and its switching is presented in this section. The hardware implementation of the model setup is shown in Fig.8. The BLDC motor selected for the hardware implementation is 24V, 6000rpm motor. The converter input voltage is 40V generated from the three phase supply using step down transformers. Implementation of hardware requires BLDC motor drive with three hall sensors, driver circuit and microcontroller. The switching signals for the model are generated from the low cost 8051 microcontroller. The gating signals are generated from the Hall sensor signals and the signals from the comparator circuit. The magnitudes of the three phase supply voltage are compared using simple OP-AMP circuits based on the Table 2. The program is written in the microcontroller to implement the gating sequence and generate the gating pulses. The gating pulses obtained are given through gate driver circuit to turn on the power switches. The gate driver circuit consists of the opto-coupler drive circuits to drive the individual switches of the matrix converter. The switching devices used for the matrix converter are IRF840. Table 3 shows the details of the matrix converter designed in the proposed work. The designed hardware setup was tested for the BLDC motor drive and found to be working satisfactorily.

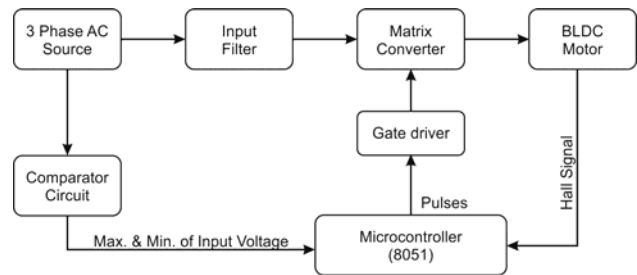

Fig.8 Proposed Hardware setup

Table 3 Matrix Converter Design Specifications

Components	Ratings	Quantity
<b>For input side</b>		
Inductor	350mH	3
Capacitor	1.5 $\mu$ F	3
<b>For Power circuit</b>		
MOSFET Switch	IRF840	18
Diode	1N4007	18
<b>For Gate Driver circuit</b>		
Optocoupler IC	MCT2E	18
Transformers	15V-0-15V, 1A	5
Bridge rectifier IC	MB1S-100V,0.5A	9
Resistors	120 $\Omega$ , 1W	18
	1K $\Omega$ , 1W	18
Capacitor	10 $\mu$ F, 100V	9

## Conclusion

This paper presents a comparative analysis of two converters- conventional DC link converter and matrix converter for driving BLDC motor with reduced supply harmonics. It is to be noted that the inverter circuit of the DC link converter draws input currents that are rich in 5<sup>th</sup> and 7<sup>th</sup> harmonics which can become a significant problem. Effort has been made to reduce the supply side harmonics using matrix converter by proposing a new switching technique. The matrix converter switching was made in such a way to produce rectangular stator currents so as to drive a BLDC motor. The new proposed switching technique and the conventional converter switching technique for driving BLDC motor have been simulated using computer simulations and the results were verified using hardware implementation. Compared to conventional DC link converter, the matrix converter reduces the supply current THD from 35% to 19%. It can be concluded that the proposed method of switching offers a very simple and effective way to modulate the matrix converters for driving brushless DC motors with reduced supply current harmonics.

## REFERENCES

- [1] Bhim singh and Sanjeev Singh, "State of Art on Permanent Magnet Brushless DC Motor Drives", Journal of power electronics, Jan (2009), Vol.9, No:1, 1-7.
- [2] Pragesan Pillay and Ramu Krishnan, "Modelling, Simulation and Analysis of Permanent Magnet Motor Drives, Part II: The Brushless DC Motor Drive", IEEE transactions on industry applications, Mar./Apr.(1989), Vol.IA-25 no.2, 274-279.
- [3] Matti Jussila, "Comparison of space vector Modulated Direct and Indirect Matrix converter in low power applications", Ph.D Thesis, Tampere university of technology (2007).
- [4] P.W.Wheeler, J.Rodriguez, J.C.Clare, L.Empringham and A.Weinstein, "Matrix Converters: A technological Review", IEEE transactions on Industrial Electronics, Apr.(2002), Vol.49, no.2, 276-288.
- [5] L.Helle, K.B.Larsen, A.H.Jorgensen, S.Munk Nielsen, F.Blaaabjaerg, "Evaluation of Modulation schemes for 3phase to 3phase matrix converter", IEEE transactions on industrial electronics, Feb (2004), Vol: 51 issue 1, 158-171.
- [6] Domenico Casadei, Givoanni serra, Angelo Tani, Luca Zarri, "Matrix converter Modualtion strategies: A new general approach based on space vactor representation of switch state", IEEE transactions on industrial electronics, Apr (2002), Vol.49, no.2.
- [7] Huber L, Borojevic D, "Space vector Modulated 3phase to 3phase matrix converter with input power factor correction", IEEE transactions on industry applications, (1995), Vol.31 no.6, 1234-1246.
- [8] Yulong Li, Namsupchoi, Byung-Moon Han, Kyoung Min Kim, Buhum Lee and Jun-Hyub Park, "Direct Duty Ratio Pulse Width Modualtion method for matrix converters", International Journal of Control Automation and Systems, Oct (2008), Vol.6 no.5, 600-669.
- [9] Sungmin Kim, Young-Doo Yoon and Seung-Ki Sui, "Pulse Width Modulation method of matrix converters for reducing output current ripple", IEEE transactions on power electronics, Oct (2010), Vol.25, no.10.
- [10] J.Karpagam, Dr.A.Nirmal Kuamr and V.Kumar Chinnaiyan, "Comparison of modulation techniques for Matrix Converter", IACSIT International Journal of Engineering and Technology, Apr (2010), Vol.2, no.2, 189-195.
- [11] Tiangui Jiang, Bozhou, Chumei Hong, Mingming Shi, "New Modulation Scheme for matrix converter driving Brushless DC Motor", International conference on Electrical machines and systems ICEMS (2008).
- [12] Bala.S, Venkataramanan.G, "Matrix Converter BLDC drive using reverse blocking IGBTs", Applied Power electronics conference and Exposition,(2006).
- [13] T.J.E.Milller, "Bruhless permanent-Magnet and Reluctance Motor Drives", Clarendon Press Oxford.
- [14] Xiaoyan Huang, Andrew Goodman, Chris Gerada, Youtong Fang, and Qinfen Lu, "A Single Sided Matrix Converter Drive for a Brushless DC Motor in Aerospace Applications" IEEE Transactions on Industrial Electronics, Sep.(2012), Vol. 59, no. 9, 3542 - 3552.

**Authors** :C.Senthil Kumar, Assistant Professor, Department of Electrical and Electronics Engineering, P.S.R.Engineering College, Sivakasi-626 140, Tamilnadu, India, E-mail: [csenthilsaro@yahoo.com](mailto:csenthilsaro@yahoo.com);  
Dr.N.Senthil Kumar, Professor, Department of Electrical and Electronics Engineering, Mepco Schlenk Engineering College, Sivakasi-626 005, Tamilnadu, India, E-mail: [nsk\\_vnr@yahoo.com](mailto:nsk_vnr@yahoo.com) ;  
M.Eswari, Assistant Professor, Department of Electrical and Electronics Engineering, Kamaraj College of Engineering and Technology, Virudhunagar - 626 001, Tamilnadu, India, E-mail: [eswari59@gmail.com](mailto:eswari59@gmail.com)