

## Use of neuronets in problems of forecasting the reliability of electric machines with a high degree of mean time between failures

**Abstract.** It was investigated the possibility to implement neuronets in reliability models of electric machines with constructive faults. It was grounded the tasks for neuronets during forecasting the failure of main structural units and electric machines in general. The choice of neuronet structure was done as result of analysis of most promising models on the example of evaluation the bearing unit faults.

**Streszczenie.** Przebadao możliwość implementacji sieci neuronowej w modelach niezawodnościowych maszyn elektrycznych z uszkodzeniami konstrukcyjnymi. Postawiono ugruntowane zadania dla sieci neuronowych podczas prognozowania uszkodzeń głównych jednostek konstrukcyjnych. Wyboru struktury sieci neuronowej dokonano w wyniku analizy najbardziej obiecujących modeli na przykładzie oceny uszkodzeń łożyska. (Wykorzystanie sieci neuronowych w prognozowaniu niezawodności maszyn elektrycznych z dużym średnim czasem między uszkodzeniami)

**Key words:** neuronet, reliability model, bearing unit.

**Słowa kluczowe:** sieć neuronowa, model niezawodnościowy, łożysko

### Introduction

Absence of reliable information as to estimated residual life is a particular feature of operation of electric machines (EM) used in industrial production. First of all, it can be explained by the fact that replacement of EMs that exhausted their limit resource is more typical for critical mechanisms. In other cases (up to 85 % of the determined number) EMs are just subjected to more thorough technical maintenance and various types of repairs aiming at restoration of their factual operating capacity. In this case the fact that such EMs operate at the last section of life-cycle curve and are characterized by a high degree of mean time between failures (MTBF) is not practically taken into consideration. They are characterized by accelerated aging and physical wear of the main structural elements and units [1–2], which, in fact, does not provide the possibility to use existing reliability models for their solution [3].

The purpose of the paper consists in grounding the principles of creation the reliability models for EM with a high degree of MTBF considering a factor of aging of the main structural units.

### Theory

Existing models of reliability, as a rule, associate reliability parameters with operating modes of EMs and their structural parameters and, practically, are not intended for taking ageing into account. More informative models assess indices of natural aging during the basic operation period. However, they mostly do not go beyond taking into account the state of the winding or preassembled structural units either, they do not associate aging processes with generation and development of unrepairable defects and are based on simplified distribution laws. During their creation designers determine relevant types of failures, operation factors and analyzed units. For example, a low- and medium-capacity induction motor reliability model, widely used in practice, enables assessment of the following components [3].

Distribution of failures caused by manufacturing defects, defect formation and aging of EM pouring-in winding insulation when the level of operational impacts corresponds to nominal operation conditions

$$(1) P_1(t) = 0.975 \cdot \exp\left[-\frac{1.4 \cdot 10^{-6}}{\vartheta - \theta} t\right] + 0.025 \cdot \exp[-5 \cdot 10^{-4} t].$$

where  $t$  – time;  $P(t)$  – probability of no-failure operation;  $\vartheta$  – current temperature of the winding;  $\theta$  – winding limiting

temperature, meeting the class of the installed insulation;  $\Delta\theta$  – excess of temperature for the given insulation class, that corresponds to twofold decrease of its operating time.

Distribution of failures caused by manufacturing defects and wear of EM iron when the level of operational impacts corresponds to nominal conditions

$$(2) P_2(t) = 0.88 \cdot 10^{-6} \cdot \exp[-2.2 \cdot 10^{-6} t] + 0.101 \cdot \exp[-0.83 \cdot 10^{-4} (t - 3.5 \cdot 10^3)]^{1.4}.$$

Distribution of failures caused by accelerated aging and wear of electrical insulating and other materials of the structure resulting from long-time motor operation when the level of operational impacts exceeds the nominal values of basic operational factors

$$(3) P_3(t) = 0.74 + 0.26 F_0 \left( \frac{t - 15.2 \cdot 10^3}{6.3 \cdot 10^3} \right),$$

where  $F_0$  – function of normal distribution.

Distribution of failures caused by quick thermal destruction of the stator winding insulation and other elements of motor structure as a result of an emergency

$$(4) P_4(t) = \exp(-0.64 \cdot 10^{-5} t).$$

Resulting dependence  $P_R(t)$  for EM, taking into account all types of failures, is created on the basis of the condition that the considered groups of failures are practically independent. It is of the form

$$(5) P_R(t) = P_1(t) P_2(t) P_3(t) P_4(t).$$

As evident from relations (1) – (5), they are based on mainly simplified exponential distribution, which does not reflect peculiar features of EM aging.

It can be explained by the absence of theoretical conceptions about EM parameters variation, components of losses in separate elements and reliable methods of their determination, as well as information about the state of the structure elements in the process of operation.

Another existing approach to assessment of reliability is of an experimental character and is based on the theory of planning an experiment (TPE). Models obtained in such a way reflect the variation of reliability indices depending on a number of diagnosed informative parameters. However, in this case the number of such parameters is limited to three, according to the method. Moreover, obtained models can be only applied to the considered EM or its structural unit and lose validity at a smallest deviation from the similarity theory.

Thus, there appears a necessity to develop new models explicitly taking into account the change of reliability indices depending on the state of the basic structural units.

Main types of EM structural unit faults influencing reliability indices were singled out in the process of research. These are various types of damages of bearing units, laminated cores, windings, shafts, whole rotors and current collection units (commutations).

Factors revealed during operation and characterizing the state of these units, change due to presence and development of particular defects. So, for collector and bearing units these are, respectively, their temperatures  $\theta_c$  и  $\theta_b$ , vibration velocity  $v$  and frequency  $n$  of rotor rotation and for winding temperature  $\theta_w$  and vibration velocity  $v$ . Vibration velocity  $v$  and current density  $J_{br}$  under the brush are typical for contact rings. I.e. every unit and element has its own influencing factors, and the degree of their variation is not reliably determined and depends on EM version, type and power. Besides, in the process of EM ageing the interconnections between the structural unit parameters and their indices become still more complicated due to change of the properties of the used materials. It proves that the use of neuronet mathematical apparatus for solution of such problems is promising [4].

In this case the most efficient approaches consist in direct realization of interconnection of the unit state and influencing factors with reliability indices or reliability forecasting depending on the degree of development of structural unit typical faults. It enables obtaining a generalized model of EM reliability in a rather simple form. However, this approach is not always applicable due to a high degree of vagueness of interconnections between parameters of separate units when a number of influencing factors is relatively great. So, it is more promising to use unit models connecting influencing factors with structural defects, which afterwards are transformed into EMs reliability models with the use of basic regulations of reliability theory.

It is proved that, in spite of seeming diversity of structural units and elements defects, their influence on EMs reliability is mainly reduced to deterioration of heat and vibration processes. It determines parameters that must be controlled by means of direct measurement: instantaneous consumed current and power, temperatures of separate units, as well as vibration velocity and its spectral components. Such set of parameters makes it possible to take into consideration random distribution and different nature of basic types of defects and damages of EMs structural units.

### Experimental research

The obtained results enabled substantiation of peculiar features of the use of neuronets in development of reliability models of structural units and whole EMs.

Relations used in the developed models and connecting the measured parameters with the state of structural units were simplified and specified up to the limit. It provided the possibility to single out significant parameters influencing, first of all, failures of units, while all the rest was referred to variant constants.

In the sphere of failures forecasting the problem for the neuronet was formulated as a prediction of EM future behavior according to the existing sequence of its previous states. According to the input measuring data  $\{X\} = \{x_1, x_2, \dots, x_n\}$  at the time moments preceding the forecasting  $x(t-1), x(t-2), \dots$  the net is to produce the solution as to the most probable value of sequence  $\bar{x}(t)$  at the current time moment  $t$  and possible state of the

analyzed EM. Factual forecasting error  $\varepsilon(t) = x(t) - \bar{x}(t)$  and its values in previous time moments  $\varepsilon(t-1), \varepsilon(t-2), \dots$  were used for adaptation of weight coefficients of the net.

In problems of state diagnostics and forecasting of structural units reliability the use of neuronet as a universal approximator of a function of several nonlinear components  $Y = F(X)$  is substantiated. In this formula  $\{X\} = \{x_1, x_2, \dots, x_n\}$  is a vector of input measuring data,  $Y$  – realization of a vector function of several variables. In this case a statistic model was used. It connected the criteria of assessment of the state of structural units with deviations of measured parameters in the form of a defect regression model of the form  $P, \lambda, T = Wa_1x_1 + Wa_2x_2 + \dots + Wa_nx_n$ , where  $P, \lambda, T$  – basic indices of unit reliability (probability of no-failure operation, failures intensity and MTBF, respectively),  $Wa_1x_1, Wa_2x_2, Wa_nx_n$  – weight coefficients.

A problem of assessment of bearing unit reliability was analyzed as an example (Fig. 1).

It can be seen in Fig. 1 that it consists of a case cap 1 with a bearing interface 3 and the bearing proper including rolling elements 4, an inner race 5 rigidly mounted on shaft 2 and an outer race 6. Due to manufacture defects and improper installation of the bearing, as well as when the case cap is flashed or skewed, such defects as crumpling of working surfaces of races and rolling elements (plastic deformation under the action of vibration, shock or statistical loads), destruction of separator (under the action of centrifugal force and impact on the separator of various-size rolling elements), destruction of races, rolling elements and the body of the machine (races skews, shock overloads) occur in the unit. In this case gaps  $\delta$  appear in interfaces, there occur shifts of the axis of bearing mounting (angle  $\alpha$ ), forces  $F$ , determining the application of the load and friction intensity, redistribute.

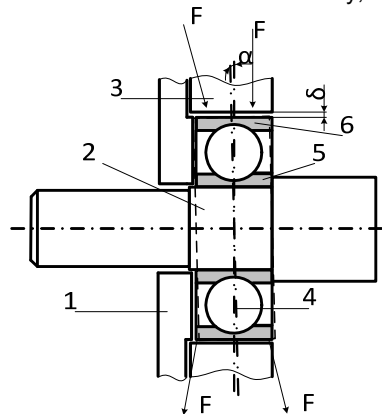

Fig. 1. Design diagram of a bearing unit

Input informative parameters include mean value of radial component of vibration velocity  $v$ , temperature  $\theta_b$  of the bearing unit, coefficient  $F_M$  of EM moment overload and separate components of the direct spectrum of vibration velocity  $v_i, \dots, v_j$  in radial and axial directions.

Under the condition of faultlessness of EM other units the developed model is to determine such structural defects of the bearing unit as bearing fit slackening (def1); balls defects (def2); journal destruction (def3); destruction of rings or housing cap (def4).

The principle of creation of reliability models implied determination of these defects with later forecasting one or several indices of reliability – in the considered case – mean time  $T$  between failures.

For development and research of the models a mathematical package [5] was preferred. The choice was based on the fact that this package provides large possibilities for work with all types of neural networks without limitation to models rigidly assigned by the neuro-simulator, and it allows designing the network required for solution of the posed problem.

Such neural networks as perseptron, recurrent Elman network and Kohonen network were analyzed during the solution (Fig. 2).

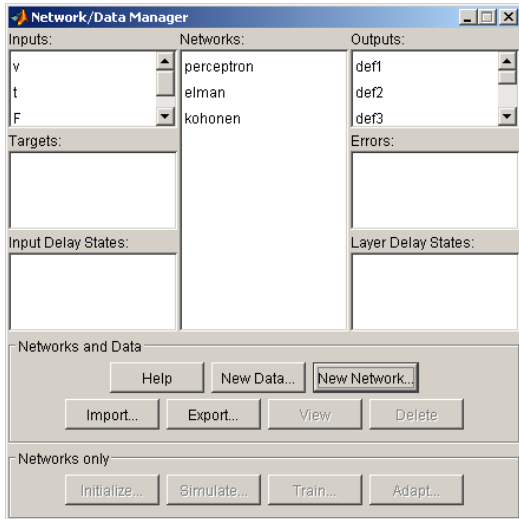

Fig.2. Analyzed neural network models realized in the package

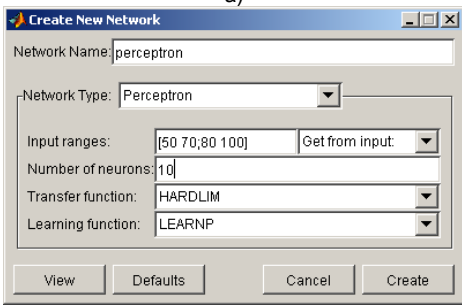
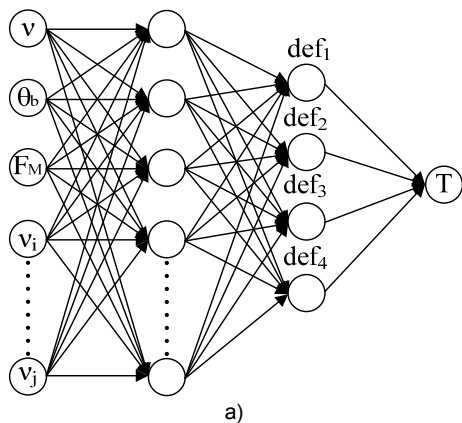

Fig. 3. Perseptron-type neural network: a – structure; b – realized model

As obvious from Fig. 3, a two-layer perseptron allows taking into account the variation of the mutual influence of informative parameters at the first buried layer of neurons, which improves the forecast of the main type defects.

Unlike perseptron, recurrent Elman network (Fig. 4) realizes feedbacks from the outputs of internal neurons. In the considered case it provides the possibility to take into account the prehistory of variation of the bearing unit and to

store information for making a true forecast of reliability indices.

Kohonen network (Fig. 5) performs the simplest functions and at its outputs generates vector  $\{Y\} = \{y_1, y_2, \dots, y_n\}$  of states reflecting mutual influence of informative parameters. The developed cards or an expert system can be used for their further identification, which will enable making conclusions as to possible defects and reliability of the unit.

To teach the networks we used the information obtained as a result of experimental research for reliability of simplified samples of a bearing unit whose general view is given in Fig. 6. This approach made it possible later to separate the housing cap influence on informative parameters variation.

Researched samples were mounted on a lathe as shown in Fig. 7.

Different operating modes corresponding to accelerated tests with variable load on the shaft were assigned by means of spatial motion of the support and measurements of informative parameters were made. The research was carried out at different kinds of friction (dry and greased) and heating modes (natural and forced) for a number of rotation frequencies and test periods.

Further defectation and assessment of the bearings state enabled connection of basic informative parameters with the degree of development of the analyzed defects.

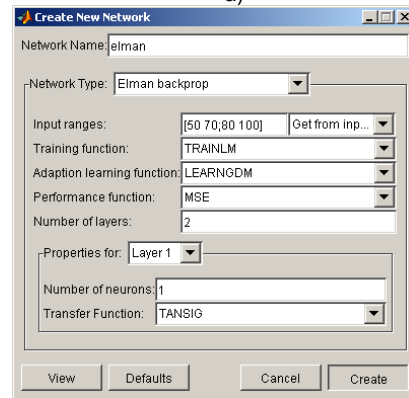
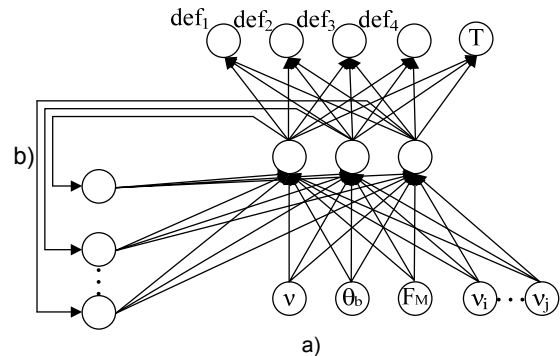

Fig. 4. Recurrent Elman network: a – structure; b – realized model

When the adequacy of the obtained models was assessed, a reliability model relating bearing unit mean time between failures to influencing factors and received with the use of TPE was also applied [6]:

$$(6) \quad T = 4644 - 1426F_M - 853v - 806\theta_b + 1021F_M v + 470F_M \theta_b - 107F_M^2 - 108v^2 - 142\theta_b^2$$

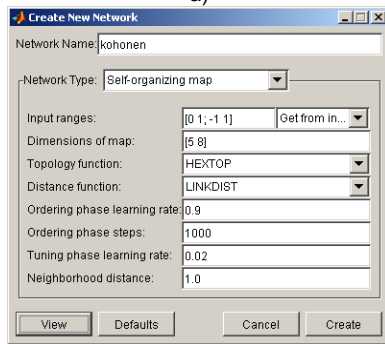
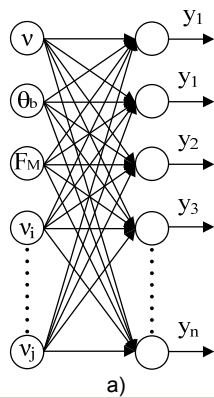

Fig. 5. Kohonen neural network: a – structure; b – realized model

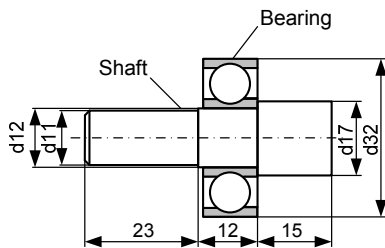

Fig. 6. General view of the researched sample of a bearing unit

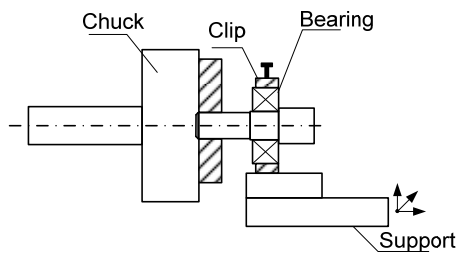

Fig. 7. Explanation of the peculiar features of the sample test

Evaluating experiments were performed with an induction motor of AOL-12-6 type with long mean time between failures and front bearing unit parameters identical to those shown in Fig.7.

Results of estimation of forecasting mean error  $\varepsilon(t)$  for an arbitrary moment of mean time between failures are given in Table1.

Table1. Results of estimation of forecasting mean error  $\varepsilon(t)$

Model type	Error $\varepsilon(t)$
Perseptron	0,063
Elman network	0,054
Kohonen network	0,079
TPE model	0,123

The use of a perseptron model of neuronet is substantiated for the solution of the posed problem. In this case every neuron modifies a calculated sum according to the analyzed indices by means of activation function in the form of a signal of presence or absence of some failure or a pre-failure state. In case of application of more structured fuzzy neuronets an output signal may be represented by a higher-level network weight coefficient determining the position of the unit within the area of admissible operating, limit and run-down states. The latter makes it possible to reduce the process of network learning to some extent.

Kohonen networks and recurrent networks also produce valid results in solution of the posed problem. However, their use requires more strict formalization of the problem, which may result in the loss of universality of the obtained solution.

## Conclusions

1. Efficiency of the use of neuronets in creation of reliability models of EMs with a high degree of MTBF has been proved.
2. The tasks of neuronets in forecasting of EM failures, state diagnostics and prediction of reliability of their basic units, the form of the used calculation model of defects and the most promising types of neuronet models used in the solution of the posed problem have been substantiated.
3. Further research direction consists in obtaining a generalized solution to the problem for the basic forms and production types of EMs, as well as in substantiation of the possibility of taking into account in the obtained models the actual modes of EM operation.

**Authors:** Mykhaylo Zagirnyak, Rector of Kremenchuk Mykhailo Ostrohradskiy National University, Professor, vul. Pershotravneva, 20, 39600, Ukraine, e-mail: [mzagirn@kdu.edu.ua](mailto:mzagirn@kdu.edu.ua); Viacheslav Prus, Associate Professor of the Department of Electric Machines and Apparatuses of Kremenchuk Mykhailo Ostrohradskiy National University, vul. Pershotravneva, 20, 39600, Ukraine, e-mail: [prus@kdu.edu.ua](mailto:prus@kdu.edu.ua)

## REFERENCES

- [1] Prus V.V., Zagirnyak M.V., Nikitina A.V., Grounds for Efficiency and Prospect of the Use of Instantaneous Power Components in Electric Systems Diagnostics, *Przeglad Elektrotechniczny*, (2006), No 12, pp. 123 – 125,.
- [2] Prus V.V., Zagirnyak M.V., Kolotylo I.A., Miljavec D., Estimate and taking into account change of steel losses in induction motors in process of their aging, *Proceedings of International IEEE Conference EUROCON 2009*. – Saint Petersburg, Russia, pp. 790–795, (2009).
- [3] Kotelenets N.F., Kuznetsov N.L., *Testing and reliability of electric machines*. – M.: Vysshaya shkola, (1988), 232 p. (in Russian).
- [4] Hamid A. Toliyat, Subhasis Nandi, Seungdeog Choi, Homayoun Meshgin-Kelk, *Electric Machines: Modeling, Condition Monitoring, and Fault Diagnosis*, CRC Press, 272 p., (2012).
- [5] *MATLAB, Simulink, User Guide*, Mathworks, 674 p., (2015).
- [6] Belluian Z.A., Belluian S.Z., Determination of acceleration factor in forced reliability tests of bearing units and synchronous generators, *Proceedings of NAS RA and GIYA*. Ser. TN. V. LIX, (2006), No.2, p. 271 – 278 (in Russian).