

doi:10.15199/48.2016.11.12

System of breath collection and analysis for diseases detection

Abstract. Collection and study of composition of the exhaled air is now intensively investigated to develop non-invasive medical diagnostics based on presence of metabolic compounds in the exhaled air. The process of collecting and processing of the exhaled air must fulfill relevant conditions to achieve satisfactory results. The paper presents the system of collecting samples of exhaled breath and the proposed methods of its analysis, using resistive gas sensors.

Streszczenie. Zbieranie oraz badanie składu wydychanego powietrza jest obecnie intensywnie rozwijaną nieinwazyjną metodą diagnostyki medycznej na podstawie występowania związków metabolicznych w wydychanym powietrzu. Proces zbierania i przetwarzania wydychanego powietrza musi spełniać odpowiednie warunki, aby uzyskać zadowalające rezultaty. W pracy przedstawiono rozwiązanie systemu zbierania próbek wydychanego powietrza oraz proponowane metody jego analizy, z wykorzystaniem rezystancyjnych czujników gazów. (**System pobierania i analizy wydychanego powietrza w procesie rozpoznawania chorób.**)

Keywords: resistive gas sensors, noise, analysis of random signals, detection of diseases.

Słowa kluczowe: rezystancyjne czujniki gazów, szумы, analiza sygnałów losowych, detekcja chorób.

Introduction

Non-invasive methods of monitoring health of patients and screening for detection of various diseases is very attractive for non-invasive medical diagnostics [1, 2]. This is particularly important because the proposed methods are relatively cheap and assure fast diagnosis, even at the cost of limited precision. The paper presents in detail how to collect samples of exhaled breath for further analysis and the concept of the prepared laboratory measurement system, using relatively inexpensive resistive gas sensors, based on functionalized gold nanoparticles with organic compounds. The proposed sensors can be selective and can detect some of organic substances emitted by the human body as a result of metabolic processes occurring there in normal state or at presence of diseases. We suppose that the emitted organic compounds increase their concentration at presence of some diseases or induce emission of other chemical compounds. The proposed procedure and the measurement system can be easily prepared and even miniaturized. Therefore, there is a serious potential for numerous applications when adequate performance will be assured.

Collecting breath samples

A proposed method of collecting and storing exhaled breath samples preserves organic chemical compound in the adsorbent. Volatile chemical compounds, being markers of various diseases in the patient's body, are exhaled in the final phase of a breath. Therefore, the system intercepting the final phase of breath was constructed. It comprises of a tube storing the final part of the exhaled breath (Fig. 1a). The preserved air sample from the tube is passed through a sterile vial containing the adsorbent (Fig. 1b). This operation can be repeated several times to increase concentration of the exhaled markers in the applied adsorber and reduce eventual errors caused by variations in the composition of gases during subsequent exhalations. The process of removing a sample of breath from the tube must be sufficiently slow and should take about ten seconds to gather gaseous substances deposited in the adsorbent. Adsorbed gas should be uniformly distributed in two layers of the adsorbent separated by cotton. The collected samples can be stored at a temperature of a few Celsius only and up to several months. This means that the storage conditions can be secured even by home refrigerator. When collecting samples should we pay attention to the conditions in the room (the possibility of gathering additional

substances emitted by the environment and equipment) and a way of patients' preparation before the test (choice of a particular and the same time of day, type of the eaten food). Control samples, taking into account the factors mentioned above, should be collected as well and used in detection process, especially in learning phase of the applied detection algorithm. The prepared system for collecting substances in the exhaled air contains an additional biological filter that prevents penetration of microorganisms into the adsorbent (Fig. 1b).

Recovery of the stored material from the adsorbent is performed during desorption process by heating the adsorbent placed in a glass vial for about 15 minutes at a temperature of about 200°C (Fig. 2). We should secure a volume of about 10-20 ml of the exhaled gases only. The recovered sample is free of moisture and can be analyzed using a set of gas sensors that are selectively sensitive to different gases.

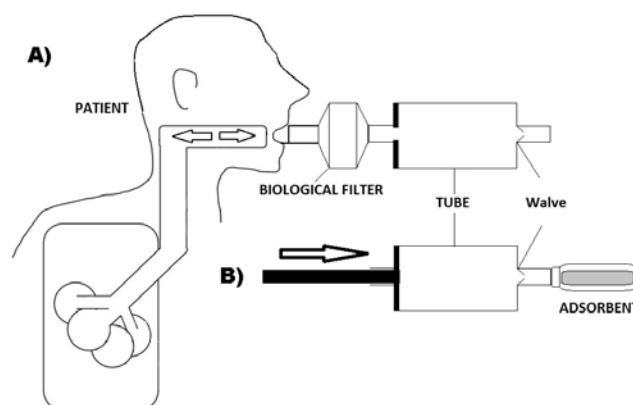

Fig.1. Illustration of a method of collecting breath samples: a) the phase of collecting exhaled breath, b) the phase of its adsorption

Measurement setup

The prepared measurement setup is composed of Teflon chamber and has a volume of about 30 ml. The applied resistive gas sensors are placed there together with pressure and temperature sensors to monitor repeatability of the measurement conditions (Fig. 3). The chamber is made of Teflon in order to avoid any interaction with the investigated organic gas mixture. The gas chamber comprises two parts screwed with bolts (Fig. 4). A silicone gasket was applied between the parts of the gas chamber to prevent any eventual leakage of the investigated gas

mixture from the chamber for at least an hour. A small volume of the chamber ensures that the analyzed gas introduced into the gas chamber by a syringe (by a needle puncture into a rubber seal) will not be significantly diluted. This is essential for ensuring effectiveness of the proposed measurement setup because the analyzed gas mixture comprises of individual chemical compounds characteristic for various diseases and their expected concentration should be well below 1 ppm [1, 4-6].

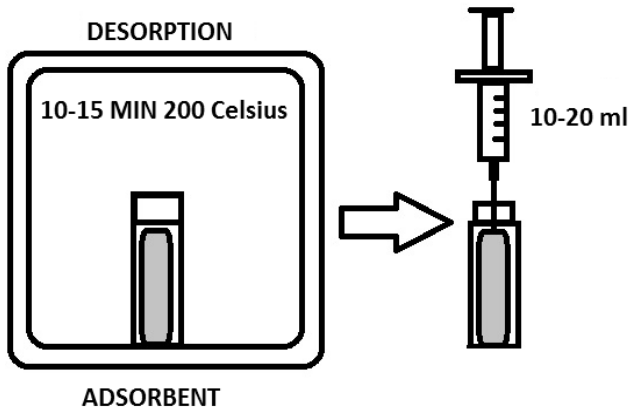

Fig.2. Illustration of a method of processing the breath sample stored in an adsorbent

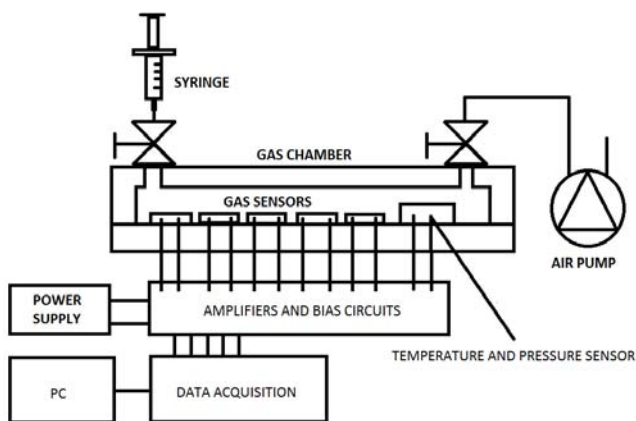

Fig.3. A block diagram of gas detection system analyzing the collected breath samples

In the prepared gas chamber we can put up to 4 different resistive gas sensors and an integrated sensor for temperature, pressure and humidity measurements (Fig. 4). The electrical connectors provide electrical contacts to all of the sensors and possibility of recording the selected signals (DC resistances or their fluctuations) in response to presence of the investigated gas mixtures. The chamber is provided with the valves allowing introduction of synthetic air deprived from moisture prior to analysis of the breaths samples. This capability limits influence of air composition in the laboratory, which can change periodically. An air pump can remove partially air from the gas chamber before introducing investigated gas mixture.

Detection of markers in the breath samples is performed by using a set of resistive gas sensors and recording changes in their DC resistances and resistance fluctuations at low frequency range, usually up to several tens of kHz only [3, 7-9].

DC resistance measurements can be done by measuring the current flowing through the sensor when the bias DC voltage up to a few volts was applied. Fluctuations phenomena were observed by biasing the sensor by a

constant current and measuring voltage fluctuations proportional to its resistance fluctuations. Such measurements can be made when the sensor is placed in a feedback loop of a low-noise operational amplifier (e.g. OPA128). The second resistor is connected to its input and is biased by a constant voltage to ensure a constant current flowing through the gas sensor. The system can be used for 1/f-like noise measurements up to tens of kHz when the resistance of the gas sensor does not exceed about 1 M Ω . Parasitic capacitances affect intensity of the observed noise when the resistance exceeds that value by limiting frequency bandwidth of the measurement system [10].

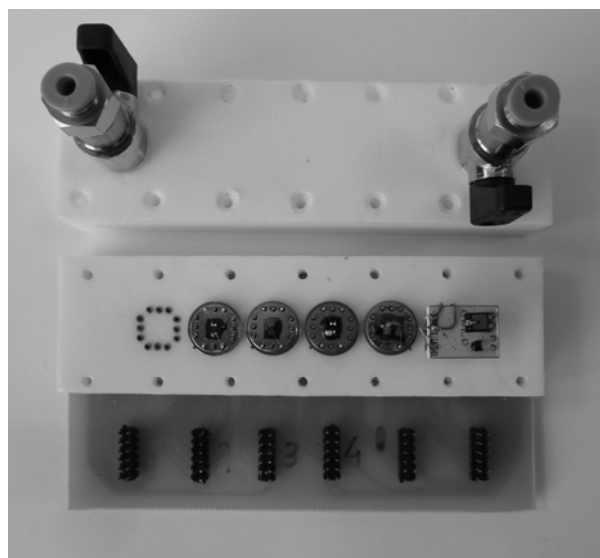

Fig.4. Picture of the prepared gas chamber made of Teflon: a substrate with a set of four gas sensors and integrated control of environmental parameters (center), connector to the sensors' terminals (bottom) and a second part of the chamber with the valves (top); the chamber is screwed using a silicone gasket to avoid eventual leakage

Noise measurements can be done using low noise operational amplifier and data acquisition board. We have applied batteries to avoid interferences from power supply lines or from other external sources. The measurement setup, including a gas chamber and the batteries, was designed to fit into the metal container securing shielding and protection against external interferences. We can apply various data acquisition cards, like National Instruments products, utilizing 24-bit A/D converter and sampling frequency up to 150 kHz in a few independent channels. Portability can be achieved by applying a USB card as well. The measurement setup can be controlled by a laptop securing necessary computations. Further miniaturization can be reached by using even a mobile phone to control the entire measuring system and miniaturized card with A/D converter and low noise voltage amplifier. At laboratory research we prefer using a spectrum analyzer (e.g. FFT Analyzer SR760 from Stanford company), which allows us to evaluate changes in power spectral density of the recorded 1/f-like noise and easily determine optimal measurement conditions (e.g. sampling frequency, averaging time, etc.). A picture of the prepared laboratory setup for noise measurements is presented in Fig. 5. A metal container is placed in the central part and holds the batteries, gas chamber and a low-noise amplifier (Fig. 6). The container is grounded and provides protection against external interference, generated mainly by power supply lines.



Fig. 5. A photograph of laboratory setup for testing exhaled air samples using DC resistances and their fluctuations

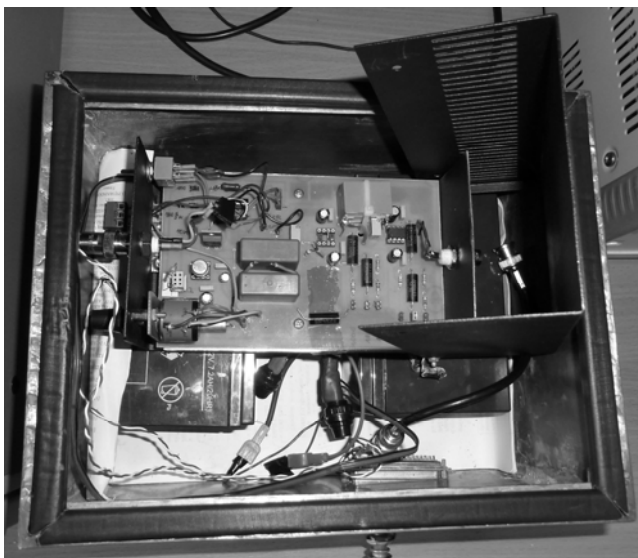

Fig. 6. A photograph of the setup to measure resistance fluctuations

The cost of the prepared gas chamber with necessary electronic units should not exceed several thousands of PLN (polish zloty). This means that the proposed method has a great potential for widespread use when a sufficiently high detection rate is assured.

The prototype sensors, optimized for detection of formaldehyde, acetaldehyde, ethanol and methane, were used (Fig. 7). These gases occur with varying intensity in the exhaled air and may be selected as the markers of various diseases. We focus on patients suffering from selected tropical diseases according to the aims of the EU research project which supports financially the performed research. Samples of exhaled air are collected in the University Center for Maritime and Tropical Medicine in Gdynia using the presented procedure. Majority of the analyzed samples are collected in tropical countries such as Colombia, Tunisia and Morocco. Samples collected in Poland will be used to demonstrate influence of race and eating habits on detection results.

The applied gas sensors are made of gold nanoparticles functionalized by organic ligands [11]. These sensors are much more selective to organic gases than commercial resistive gas sensors (e.g. offered by Figaro company).

Moreover, the sensors operate at room temperature, which is very important for organic compounds detection.

The sensors are prepared by placing on the golden

electrodes the gas sensing layer. The bounded wires assure electrical contacts (Fig. 7). DC resistance between the electrodes depends on thickness of gas sensing layer and a way of its functionalization by organic ligand. Each sensor uses four electrodes to eliminate eventual noise generated in contact area between the golden electrode and a gas sensing layer. Two electrodes are used to bias the sensor with a constant current while two other are used to measure voltage fluctuations. The method was described in detail in literature [12]. DC resistances of the prepared sensors did not exceed a few hundred of $k\Omega$ at ambient atmosphere of synthetic air and decreased during the measurements when we used formaldehyde or carbon monoxide up to a few ppm only.

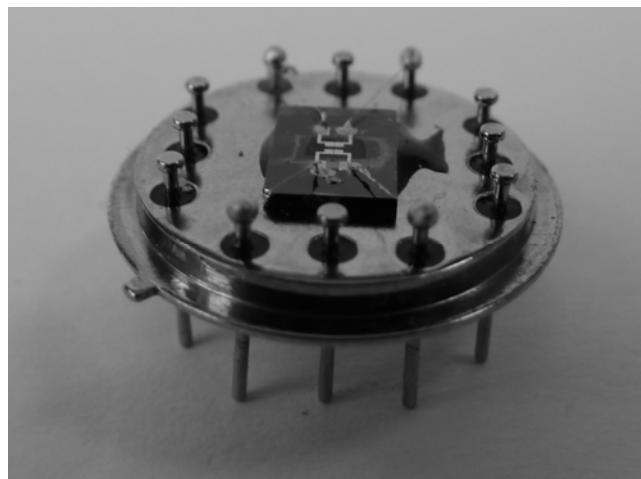

Fig. 7. A picture of the applied resistive gas sensor with visible wired contacts from the electrodes covered by gas sensing layer

When a data acquisition card is used we can record even a few millions of voltage fluctuations samples at the output of the operational amplifier operating in a mode of a low noise voltage amplifier. Various statistical functions can be estimated to characterize random signals. Due to a complexity of necessary calculations and acquisition time, the analysis is usually limited to determining the power spectral density of resistance fluctuations. We apply Welch method to estimate power spectral density [13]. Initial studies assumed averaging over 100 spectra to reduce random error to 10% only and keeping the measurement time to several tens of seconds. It means that our laboratory setup can record data from four sensors within 4-5 minutes only.

Methods of data analysis

The recorded measurement data can be analyzed by various detection algorithms. Any changes in DC resistances in an array of sensors are used as an input data vector for detection algorithm. A popular Principal Component Analysis (PCA) algorithm is applied. It determines the most informative resistances or their changes for accurate detection. Even better results can be provided by non-linear methods (e.g. Support Vector Machine – SVM) due to non-linear response of the sensors to various gas mixtures.

When fluctuation enhanced sensing (FES) method, utilizing resistance fluctuations, is used the same detection algorithms can be applied as well. The main difference is an input data vector. The FES method utilizes as an input vector a power spectrum density function. It has been reported that the method can detect a few different gases by a single sensor only [14]. The research project unifies various data formats using different sensors and gas

detection methods to share measurement results between research teams, realizing the project. This approach allows you to evaluate effectiveness of the proposed research methods in different environments and research laboratories. A particularly important for project results is evaluation of food habits impact or race on detection of the selected tropical diseases.

Conclusions

We have presented the measurement setup developed to study breath samples of healthy patients or patients suffering from selected parasitic diseases popular in tropical zone, but occurring in Poland as well (a number of patients suffering from *Echinococcus multilocularis* does not exceed a few hundred per year in Poland). A comparative study with breath samples of the patients from tropical countries will be performed in the next phase of the research project. Some of the investigated tropical diseases are very common in developing countries and cause severe economic problems.

The presented system was tested using calibrating gases (e.g. formaldehyde, carbon monoxide, synthetic air) available in the laboratory. It will be presently applied to analyze exhaled breath samples from healthy and ill patients. The developed system uses the methods based on measurements and analysis of DC resistances and 1/f-like resistance noise, depending on composition of the ambient atmosphere around the gas sensors.

This research was done thanks to financial support by the European Union project Horizon 2020, Subprogramme H2020-MSCA-RISE-2014 "Development of a non-invasive breath test for early diagnosis of tropical diseases", run by Gdańsk University of Technology.

Authors: mgr inż. Tomasz Chludziński, Politechnika Gdańska, Wydział Elektroniki, Telekomunikacji i Informatyki, Katedra Metrologii i Elektroniki, ul. G. Narutowicza 11/12, 80-233 Gdańsk, E-mail: tomekchlud@gmail.com; dr hab. inż. Janusz Smulko, prof. nadzw. PG, Politechnika Gdańska, Wydział Elektroniki, Telekomunikacji i Informatyki, Katedra Metrologii i Elektroniki, ul. G. Narutowicza 11/12, 80-233 Gdańsk, E-mail: jsmulko@eti.pg.gda.pl

REFERENCES

- [1] Hakim M., Broza Y. Y., Barash O., Peled N., Phillips M., Amann A., Haick H., Volatile organic compounds of lung cancer and possible biochemical pathways, *Chem. Rev.*, 112 (2012), 5949-5966
- [2] Mazzone P., Progress in the development of a diagnostic test for lung cancer through the analysis of breath volatiles, *J. Breath Res.*, 2 (2008), 037014
- [3] Kotarski M., Smulko J., Hazardous gases detection by fluctuation enhanced gas sensing, *Fluctuations and Noise Lett.*, 4 (2010), 359-371
- [4] Peng G., Tisch U., Adams O., Hakim M., Shehada N., Broza Y.Y., Billan S., Abdah-Bortnyak R., Kuten A., Haick H., Diagnosing lung cancer in exhaled breath using gold nanoparticles, *Nat. Nanotechnol.*, 4 (2009), 669-73
- [5] Fuchs P., Loeseke C., Schubert J.K., Miekisch W., Breath gas aldehydes as biomarkers of lung cancer, *Int. J. Cancer*, 126 (2010), 2663-2670
- [6] Španěl P., Smith D., Quantification of trace levels of the potential cancer biomarkers formaldehyde, acetaldehyde and propanol in breath by SIFT-MS, *J. Breath Res.*, 2 (2008), 046003
- [7] Kish L.B., Vajtai R., Granqvist C.G., Extracting information from noise spectra of chemical sensors: single sensor electronic noses and tongues, *Sens. Actuators B*, 71 (2000), 55-59
- [8] Dziejdzic A., Kolek A., Licznarski B.W., Noise and nonlinearity of gas sensors – preliminary results, *Proc. 22nd Int. Spring Seminar on Electronics Technology*, (1999), 99-104
- [9] Macku R., Smulko J., Koktavy P., Trawka M., Sedlak P., Analytical fluctuation enhanced sensing by resistive gas sensors, *Sens. Actuators B*, 213 (2015), 390-396
- [10] Ayhan B., Kwan C., Zhou J., Kish L.B., Benkstein K.D., Rogers P.H., Semancik S., Fluctuation enhanced sensing (FES) with a nanostructured, semiconducting metal oxide film for gas detection and classification, *Sens. Actuators B*, 188 (2013), 651-660.
- [11] Ionescu R., Espinosa E.H., Leghrib R., Felten A., Pireaux J.J., Erni R., & Llobet E., Novel hybrid materials for gas sensing applications made of metal-decorated MWCNTs dispersed on nano-particle metal oxides, *Sens. Actuators B*, 131 (2008), 174-182
- [12] Smulko J., Szumy czujników – metody pomiarów i analizy, *Wydawnictwo Politechniki Gdańskiej* (2014)
- [13] Bendat J.S., Piersol A.G., Random data: analysis and measurement procedures, *John Wiley & Sons* (2011)
- [14] Lentka Ł., Smulko J.M., Ionescu R., Granqvist C.G., Kish L.B., Determination of gas mixture components using fluctuation enhanced sensing and the LS-SVM regression algorithm, *Metrol. Meas. Syst.*, 22 (2015), 341-350