

## New Current-mode Quadrature Sinusoidal Oscillator Using Single DVCCTA as Active Element

**Abstract.** This paper presents the design of a current-mode quadrature sinusoidal oscillator. It can generate two current-mode sinusoidal outputs with 90 degree phase difference called as quadrature signal. The proposed sinusoidal oscillator employs single differential voltage current conveyer transconductance amplifier (DVCCTA), two grounded capacitors and three resistors. The tuning of frequency of oscillation (FO) and condition of oscillation (CO) can be done independently. Also the frequency of oscillation can be electronically tuned which is suitable for modern control system using microcontroller or microprocessor. The impedance at output node is high impedance which can directly drive an external load or connect to another circuit without the use of current buffers. A number of simulation results based on PSPICE program using 0.25  $\mu\text{m}$  TSMC CMOS parameters are included to exhibit performance, workability and effectiveness of the proposed sinusoidal oscillator.

**Streszczenie.** W artykule opisano projekt prądowego generatora sinusoidalnego. Może on generować sygnały z przesunięciem 90°. Generator wykorzystuje różnicowy przetwornik napięcie prąd ze wzmacniaczem transkonduktancyjnym – DVCCTA., dwa uziemione kondensatory i trzy rezystory. Generator może być strojony elektronicznie. Nowy generator sinusoidalny wykorzystujący jako aktywny element układ DVCCTA.

**Keywords:** quadrature sinusoidal oscillator; current-mode; DVCCTA.

**Słowa kluczowe:** generator sinusoidalny, układ DVCCTA.

### Introduction

In electrical and electronic engineering, the sinusoidal signal has gained much of importance. The circuit which generates the sine wave is called as oscillator. Ideally, the oscillator should generate the sinusoidal signal with low total harmonic distortions (THD). Especially, the quadrature sinusoidal oscillator which provides two sinusoidal signals with 90° degree phase difference is very useful in many applications, for example, in measurement system found in vector generators and in selective voltmeters and in telecommunication found in single sideband modulators, in quadrature mixers, in direct-conversion receivers etc. [1-4]. "The synthesis of analog signal processing circuits using active building blocks, taking into account several various criteria such as minimum number of active elements or others, has been receiving considerable attention [5]. Recently, a new mixed-mode active element, namely, differential voltage current conveyer transconductance amplifier (DVCCTA), was introduced [6]. This building block with two voltage inputs and two kinds of output current is constructed from the well-known advantages of the differential voltage current conveyer (DVCC) and the operational transconductance amplifier (OTA). It provides the facility for the implementation of voltage and current mode signal processing. Moreover, its transconductance gain ( $g_m$ ) can be electronically tuned which is easy to use in the modern microcontroller or microprocessor based electronic systems." [7]. A lot of electronic circuits using DVCCTA have been proposed in literature which can be found in [6-15]. Most of them were introduced for analog signal processing for example, capacitance multiplier [6], inductance simulator [8], first order allpass filter [8-9], wave active filter [10], multifunction filter [11-13] and sinusoidal oscillator [7, 9, 14-15]. In this study, the oscillator using DVCCTA as active element will be focused and reviewed. The voltage-mode quadrature oscillator consisting of single DVCCTA, two grounded capacitors and two grounded resistors was proposed [14]. The condition of oscillation and frequency of can be orthogonally controlled. The frequency of oscillation can be electronically adjusted. However, the frequency of oscillation and condition of oscillation cannot be electronically tuned. The sinusoidal oscillator in [9] was designed from the connecting of first order allpass filter and integrator. It consists of two DVCCTAs, two grounded

capacitors and two grounded resistors. The circuit can provide quadrature signal in both voltage and current mode. The frequency of oscillation can be electronically tuned. However, it cannot provide the independent control of frequency of oscillation and condition of oscillation. Two current-mode sinusoidal oscillators were proposed in [15]. The first one consists of single DVCCTA, two grounded capacitors and two grounded resistors. The frequency of oscillation and condition of oscillation can be orthogonally controlled. However, the frequency of oscillation cannot be electronically adjusted. Moreover, this circuit cannot provide quadrature output waveform. The second oscillator consists of single DVCCTA, two grounded capacitors and single resistor. The frequency of oscillation can be electronically tuned. However, condition of oscillation is tuned by adjusting the value of two capacitors. Also, this circuit cannot provide quadrature output waveform. Recently, the voltage-mode quadrature oscillator using DVCCTA was proposed [7]. This quadrature oscillator consists of single DVCCTA, two grounded capacitors and single resistor. The frequency of oscillation and condition of oscillation can be electronically tuned. However, it cannot provide the independent control of frequency of oscillation and condition of oscillation. In 2011, the current-mode quadrature sinusoidal oscillator was presented [3]. This oscillator consists of single active building block which is widely used in current-mode signal processing [16-17], namely current controlled current differencing transconductance amplifier (CCCDTA) and two grounded capacitors. In this oscillator, the frequency of oscillation and condition of oscillation can be electronically controlled. Moreover, the two output current nodes are exhibit high impedance which allows circuit can be cascaded to other circuit without the use of any buffers. However, the frequency of oscillation and condition of oscillation cannot be independently tuned.

In this paper, a current-mode sinusoidal oscillator, consisting of single DVCCTA, two grounded capacitors and three resistors is proposed. It can provide quadrature sinusoidal waveform in current-mode with high output impedance. The frequency of oscillation and condition of oscillation can be independently adjusted. Also, the frequency of oscillation can be electronically tuned. The simulation results using PSpice program agree well with theoretical anticipation.

## Theory and Principle

### Basic Concept of DVCCTA

The realization of electronic circuits using active building block has been gained significant attention [18-23]. In this realization, the differential voltage current conveyer transconductance amplifier (DVCCTA) is main active building block. It was firstly proposed in [6]. DVCCTA is constructed from the well-known differential voltage current conveyer (DVCC) and operational transconductance amplifier (OTA). An electrical symbol of DVCCTA is ideally given in Fig. 1(a) and its electrical symbol is shown in Fig. 1(b). According to Fig. 1, it is found that DVCCTA is a five terminal active device. Ideally, the voltage input terminals  $Y_1$  and  $Y_2$  are high impedance, while  $X$  terminal is low impedance. The current output terminals  $Z$  and  $O$  are high impedance. The voltage at  $Z$  terminal is sent to be current at  $O$  terminal via transconductance ( $g_m$ ). The DC bias current  $I_B$  is used to control the transconductance of the current at  $O$  terminal. The input and output terminal relations of DVCCTA can be characterized by the matrix shown as follows

$$(1) \begin{pmatrix} I_{Y1} \\ I_{Y2} \\ V_X \\ I_Z \\ I_O \end{pmatrix} = \begin{pmatrix} 0 & 0 & 0 & 0 & 0 \\ 0 & 0 & 0 & 0 & 0 \\ 0 & 1 & -1 & 0 & 0 \\ 1 & 0 & 0 & 0 & 0 \\ 0 & 0 & 0 & \pm g_m & 0 \end{pmatrix} \begin{pmatrix} I_X \\ V_{Y1} \\ V_{Y2} \\ V_Z \\ V_O \end{pmatrix}.$$

The CMOS implementation of DVCCTA can be shown in Fig. 4. Assume that  $M_{14}$ - $M_{15}$  are matched and operating in saturation region, the gm are written as

$$(2) \quad g_m = \sqrt{\mu_n C_{ox} (W/L) I_B}.$$

$I_B$  are the input bias current to control gm and is used to control the gm.  $\mu$  is the effective channel mobility.  $C_{ox}$  is the gate oxide capacitance per unit area.  $W$  is the channel width and  $L$  is the channel length.

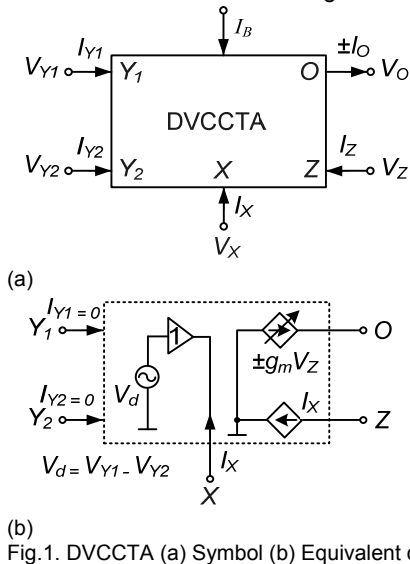

Fig.1. DVCCTA (a) Symbol (b) Equivalent circuit [7]

### Implementation of Quadrature Sinusoidal Oscillator

The generalized structure of the quadrature sinusoidal oscillator is shown in Fig. 2 which consists of the two lossless integrators and amplifier. The parameters  $a$  and  $b$  are the time conductance of integrators, respectively. The  $k$  is the gain of current amplifier. From block diagram in Fig. 2, the characteristic equation is written as

$$(3) \quad s^2 ab + sa(k-1) + 1 = 0.$$

Considering in Eq. (3), the frequency of oscillation and condition of oscillation are expressed as

$$(4) \quad \text{OF: } \omega = \sqrt{\frac{1}{ab}},$$

and

$$(5) \quad \text{OC: } 1 \geq k.$$

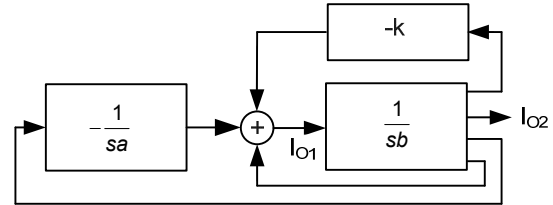

Fig.2. The generalized structure of current-mode quadrature sinusoidal oscillator

Considering Eqs. (4) and (5), the CO can be controlled independently of the FO by the current gain  $k$ , while the FO can be changed by  $a$  and  $b$  without affecting CO.

The relationship between output current  $I_{O1}$  and  $I_{O2}$  is as follows:

$$(6) \quad \frac{I_{O1}}{I_{O2}} = \frac{1}{sb}$$

It is found from Eq. (6) that the phase difference between  $I_{O1}$  and  $I_{O2}$  are 90 degree which is the quadrature signal.

### Proposed Current-mode Quadrature Sinusoidal Oscillator

Based on the block diagram in Fig. 2, the proposed current-mode quadrature sinusoidal oscillator is illustrated in Fig. 3. It consists of one DVCCTA, three resistors and two grounded capacitor. The quadrature output currents are  $I_{O1}$  and  $I_{O2}$ . It is found that the proposed oscillator uses only single active elements with grounded capacitors which is attractive for monolithic chip point of view. Moreover, the impedance of the output currents is high impedance which can be cascaded or driven external load without the use of buffering circuit. From the circuit in Fig. 3, the characteristic equation is obtained as

$$(7) \quad s^2 C_1 C_2 R_x + s C_1 (R_2 - R_1) + g_m = 0.$$

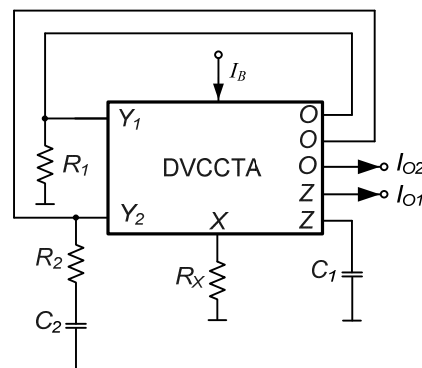

Fig.3. DVCCTA-based current-mode quadrature sinusoidal oscillator

According to Eqs. (4) and (5), the FO and CO are as follows:

$$(8) \quad \text{OF } \omega = \sqrt{\frac{g_m}{C_1 C_2 R_x}},$$

and

$$(9) \quad \text{CO: } R_1 \geq R_2.$$

If  $g_m$  is equal to Eq. (2), the FO in Eq. (8) is written as

$$(10) \quad \text{FO: } \omega = \sqrt{\frac{(\mu_n C_{OX} (W/L) I_B)^{\frac{1}{2}}}{C_1 C_2 R_x}}.$$

From Eqs. (9) and (10), it can be seen that the FO can be adjusted electronically/independently from the CO by varying  $I_B$  while the CO can be adjusted independently from the FO by  $R_1$  and  $R_2$ .

### Analysis of Non-ideal Case

In practically, the characteristic of DVCCTA is written as

$$(11) \quad V_x = \beta_1 V_{y1} - \beta_2 V_{y2}; I_z = \alpha i_x; I_o = \gamma g_m V_z,$$

where  $\alpha$  is the parasitic current transfer gains from X terminals to Z terminal.  $\beta_1$  and  $\beta_2$  are the parasitic voltage transfer gains from  $Y_1$  and  $Y_2$  terminals to X terminal.  $\gamma$  is the parasitic current gains associated with copies of the current from o terminal.

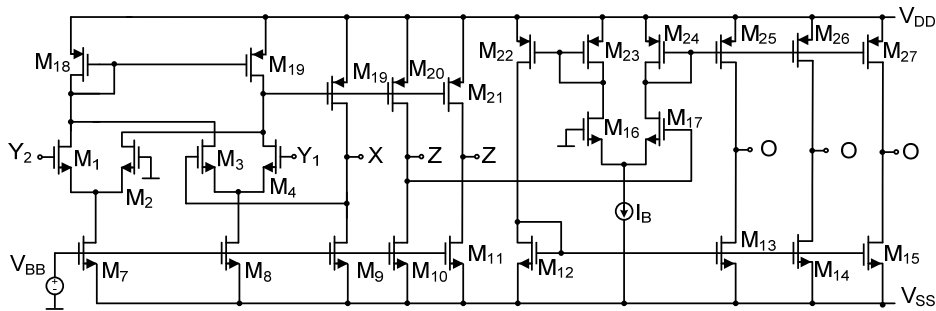

Fig.4. Internal construction of DVCCTA

### Simulation Results

To verify the theoretical analysis, the proposed oscillator was simulated with PSPICE simulation using CMOS schematic of DVCCTA as given in Fig. 4. The circuit was designed and simulated based on the 0.25 $\mu$ m TSMC CMOS technology [24]. The optimal aspect ratios of PMOS and NMOS transistor are listed in Table 1. The active parameters and the passive elements in the proposed oscillator are chosen as  $\pm 1.25$ V supply voltages,  $V_{BB} = -0.55$ V,  $R_1 = 1.35$ k $\Omega$ ,  $R_2 = 1$ k $\Omega$ ,  $R_x = 3.8$ k $\Omega$ ,  $C_1 = C_2 = 33$ pF and  $I_B = 70$  $\mu$ A. The transient responses from initial state until steady state and during the steady state are respectively shown in Fig. 5 and 6. It is found that the output currents  $I_{O1}$  and  $I_{O2}$  are quadrature signal. Figure 7 shows the output spectrums. The simulated frequency of oscillation achieved 1.36 MHz. The total harmonic distortions (THD) for  $I_{O1}$  and  $I_{O2}$  are 2.054% and 2.359%, respectively.

Table 1. Aspect ratio W/L for MOSFETs

Transistor	W ( $\mu$ m)	L ( $\mu$ m)
M1-M4	1	0.25
M7-M15	3	0.25
M16-M17	2	0.25
M18-M21	15	0.25
M22-M27	5	0.25

Considering the non-ideal effects, characteristic equation get modified to

$$(12) \quad s^2 C_1 C_2 R_x + s C_2 \alpha \gamma g_m (\beta_2 R_2 - \beta_1 R_1) + \alpha \beta_2 \gamma g_m = 0.$$

Then the frequency of oscillation and condition of oscillation of the proposed current-mode quadrature oscillator from Eqs.(8)-(9) become

$$(13) \quad \text{FO: } \omega = \sqrt{\frac{\alpha \beta_2 \gamma g_m}{C_1 C_2 R_x}},$$

and

$$(14) \quad \text{CO: } R_1 \geq \frac{\beta_2}{\beta_1} R_2.$$

It is found that non-ideal parameters will affect both frequency of oscillation and condition of oscillation. These parameters are dependent on temperature variations. Consequently, these errors affect the sensitivity to temperature and the high frequency response of the proposed circuit, the DVCCTA should be carefully designed to minimize these errors. Moreover, the stray/parasitic capacitance at terminal  $y_1$ ,  $y_2$ , z and o, can be absorbed into the external grounded capacitors as they appear in shunt with them.

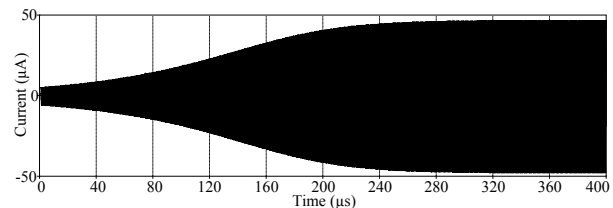

Fig.5. Output waveforms during initial

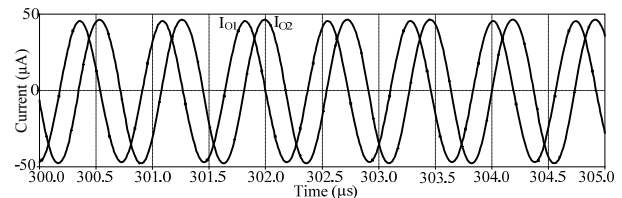

Fig.6. Output current of the proposed quadrature sinusoidal oscillator

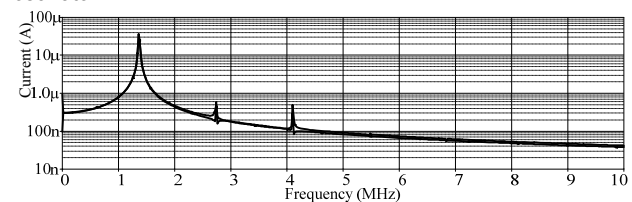

Fig.7. Spectrum of signal in Fig.6

## Conclusions

In this paper, a current-mode quadrature sinusoidal oscillator employing single DVCCTA, two grounded capacitors and three resistors is presented. The main advantage of proposed oscillator is that it employs only single active element which is useful for integrated circuit implementation. It can provide current-mode quadrature sinusoidal signals ( $I_{O1}$  and  $I_{O2}$ ) with high output impedance resulting in easy cascading with other current-mode circuits or directly driving load without the use of current buffer. The tuning of frequency of oscillation and condition of oscillation is independently. The frequency of oscillation can be electronically controlled which is easy for microcontroller or microcomputer controllability. The performances of the proposed oscillator were verified by PSpice simulation results, which show strong agreement with the theoretical analyses.

*Acknowledgments.* This work is funded by Suan Sunandha Rajabhat University.

**Authors:** Prungsak Uttaphut, Department of Electrical Technology, Faculty of Industrial Technology, Suan Sunandha Rajabhat University, Dusit, Bangkok, 10300, Thailand E-mail: [prungsak.ssr@gmail.com](mailto:prungsak.ssr@gmail.com).

The correspondence address is:  
e-mail: [prungsak.ssr@gmail.com](mailto:prungsak.ssr@gmail.com)

## REFERENCES

- [1] Summart, S., Thongsopa, C., Jaikla, W., OTA based current-mode sinusoidal quadrature oscillator with non-interactive control, *Przegląd Elektrotechniczny*, 88 (2012), n 7A, 14-17
- [2] Khan I. A., Khawaja S. An integrable gm-C quadrature oscillator, *International journal of electronics*, 87 (2000);1353-1357
- [3] Keawon, R. Jaikla, W. A resistor-less current-mode quadrature sinusoidal oscillator employing single CCCDTA and grounded capacitors, *Przegląd Elektrotechniczny*, 8 (2011), 138-141
- [4] Khateb, P., Jaikla, P. Kuba'nek, D., Khatib, N., Electronically tunable voltage-mode quadrature oscillator based on high performance CCCDBA, *Analog Integrated Circuits and Signal Processing*, 74 (2013), n 3, 499-505
- [5] Bielek, D., Senani, R., Biolkova, V., Kolka, Z., Active elements for analog signal processing, classification, review and new proposals, *Radioengineering*, 17 (2008), n. 4, 15-32
- [6] Jantakun, A., Pisutthipong, N., Siripruchyanun, M., Single element based-novel temperature insensitive/electronically controllable floating capacitance multiplier and its application, *International Conference on Electrical Engineering/Electronics Computer Telecommunications and Information Technology (ECTI-CON)*, (2010), 37-41.
- [7] Tuntrakool, S., Jaikla, W., Suwanjan, P., Single DVCCTA based voltage-mode quadrature sinusoidal oscillator with electronic controllability, *2014 European Modelling Symposium (EMS)*, (2014), 462-465
- [8] Nandi, R. Venkateswaran, P., Kar, M., MMCC based electronically tunable allpass filters using grounded synthetic inductor, *Circuits and Systems*, 5 (2014), pp. 89-97
- [9] Pandey, N., Pandey, R., Paul, S. K., A first order all pass filter and its application in a quadrature oscillator, *Journal of Electron Devices*, 12 (2012), 772-777
- [10] Pandey, N., Kumar, P., Differential voltage current conveyor transconductance amplifier based wave active filter, *Journal of Electron Devices*, 10 (2011), 429-432
- [11] Pandey, N., Paul, S. K., VM and CM universal filters based on single DVCCTA, *Active and Passive Electronic Components*, (2011), Article ID 929507
- [12] Maiti, S. Pal, R. R., Universal biquadratic filter employing single differential voltage current controlled conveyor transconductance amplifier, *Lecture Notes on Photonics and Optoelectronics*, 1 (2013), no. 2, 56-61
- [13] Ratale, J. S., Mungona, S. S., Active filter based on differential voltage current conveyor transconductance amplifier (DVCCTA), *International Journal of Advanced Research in Computer Science and Software Engineering*, 4 (2014), no. 1, 329-335
- [14] Lahiri, A., Jaikla, W., Siripruchyanun, M., Voltage-mode quadrature sinusoidal oscillator with current tunable properties, *Analog Integrated Circuits and Signal Processing*, 65 (2010), no. 2, 321-325
- [15] Chein, H. C., Chen, C. Y., CMOS realization of single-resistance-controlled and variable frequency dual-mode sinusoidal oscillators employing a single DVCCTA with all-grounded passive components, *Microelectronics Journal*, 45 (2014), no. 2, 226-238.
- [16] Jaikla, W., Khateb, F., Siripongdee, S., Supavarasuwat, P., Suwanjan, P., Electronically tunable current-mode biquad filter employing CCCDTAs and grounded capacitors with low input and high output impedance, *AEU - International Journal of Electronics and Communications*, 67 (2013), n 12, 1005-1009
- [17] Jantakun, A., Jaikla, W., Current-mode quadrature oscillator based on CCCDTAs with noninteractive dual-current control for both condition of oscillation and frequency of oscillation, *Turkish Journal of Electrical Engineering and Computer Sciences*, 21 (2013), n 1, 81-89
- [18] Jaikla, W., Noppakarn, A., Lawanwisut, S., New gain controllable resistor-less current-mode first order allpass filter and its application, *Radioengineering*, 21 (2012), n 1, 312-316
- [19] Jaikla, W., Siripongdee, S., Suwanjan, P., MISO current-mode biquad filter with independent control of pole frequency and quality factor, *Radioengineering*, 21 (2012), n 3, 886-891
- [20] Jaikla, W., Bielek, D., Siripongdee, S., Bajer, J., High input impedance voltage-mode biquad filter using VD-DIBAs, *Radioengineering*, 23 (2014), n 3, 914-921
- [21] Khateb, F., Khatib, N., Prommee, P., Jaikla, W., Fucjik, L., Ultra-low voltage tunable transconductor based on bulk-driven quasi-floating-gate technique, *Journal of Circuits, Systems and Computers*, 22 (2013), n 8, Article number 1350073
- [22] Lahiri, A., Jaikla, W., Siripruchyanun, M., First CFOA-based explicit-current-output quadrature sinusoidal oscillators using grounded capacitors, *International Journal of Electronics*, 100 (2013), n 2, 259-273
- [23] Ninsraku, W., Bielek, D., Jaikla, W., Siripongdee, S., Suwanjan, P., Electronically controlled high input and low output impedance voltage mode multifunction filter with grounded capacitors, *AEU - International Journal of Electronics and Communications*, 68, Issue 12, 1 December 2014, Pages 1239-1246
- [24] Prommee, P., Angkeaw, K., Somdunyanok, M., Dejhan, K., CMOS-based near zero-offset multiple inputs max-min circuits and its applications, *Analog Integrated Circuits and Signal Processing*, 61 (2009), pp. 93-105