

doi:10.15199/48.2017.11.27

High specific power HTS electric machines

Abstract. Nowadays More Electric Aircraft is already flying. The next step is development of all-electric airplane with fully new propulsion system. One of the key parameters of electric propulsion system is the specific power. Electrical machines are major components of such system. Therefore we need to increase the specific power of electrical machines. The usage of superconductivity allows to increase efficiency and power-to-weight ratio of all electrical systems of the aircraft. This work reviews potential specific power values of fully superconducting machines.

Streszczenie. Maszyny elektryczne są ważnym komponentem w lotnictwie. Zastosowanie w nich materiałów nadprzewodnikowych pozwala na znaczące zmniejszenie stosunku mocy do wagi. **Elektryczne maszyny nadprzewodnikowe o dużej mocy**

Keywords: superconducting motor, HTS, high specific power electrical machines.

Słowa kluczowe: maszyny nadprzewodnikowe, maszyny elektryczne.

Introduction

One of the key parameters of electric propulsion system is the specific power.

The development of all-electric aircraft requires the electrical machines with high specific power (20 kW/kg and more). Whereas conventional electrical machines possess the specific output power of 5 kW/kg without control and cooling systems [1], because they contain ferromagnetic core and copper windings. Thus, if we want to increase power of conventional electrical machine we need to increase its weight and size.

The increasing of specific power of electrical machine is possible with the use of superconducting windings. Modern high temperature superconductors (HTS) have high transport current density – more than 500 A/mm² [2]. This allows to increase electromagnetic loadings of the machine and increase its power. But development of such type of machine is very difficult scientific and engineering problem due to specific properties of modern HTS tapes. Besides HTS machines operate in extremely cold temperatures of liquid nitrogen (77K) and lower.

Principal scheme of HTS machines

Useful superconducting power devices, especially electric machines, have been developed, in particular for producing strong dc magnetic fields [3, 4, 12]. But such machines have only field HTS coils and copper armature coils and their specific power is not high enough for application at the aircraft. AC losses in superconductors have made it difficult to create practical and useful fully superconducting rotating machines. Thanks to improvement of properties of HTS wire AC windings in electrical machines can be made of them. Application of HTS field and armature coils will increase magnetic induction in the air gap and electric load of the stator. Both induction and electric load influences output power [5]. More than that fully HTS machine can be made without rotating cryostat. This construction element is very difficult to produce due to sealing problems.

That is why we need to use fully superconducting electric machines. Unfortunately, there are no methodologies for calculating parameters of fully HTS electrical machines and we need to develop them. More than that, we need to use new approaches to constructing and design of such machines.

As known superconducting tapes have critical parameters such as temperature, magnetic field and current. Mechanical properties of HTS are also very important. For example modern HTS tapes have minimal band radius 22 mm [6]. That is why it is impossible to

produce conventional windings using them. Our experience in the field of HTS electrical machines shows that racetrack coils (Fig. 1) are the only way to use modern HTS tapes as windings [3, 7]. Therefore principal scheme of fully HTS machine is the scheme with racetrack coils on stator and rotor (fig. 2).

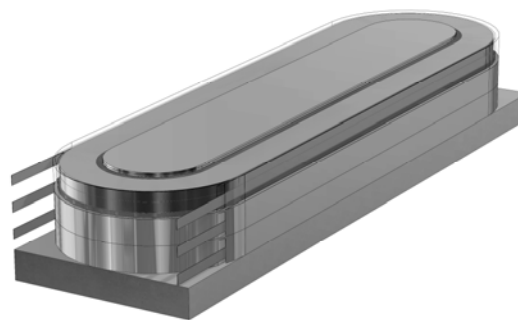

Fig.1. HTS racetrack coils

More than that scheme of the machine can be different in the terms of the active materials. It means that machine can possess two schemes. The first is the scheme with two ferromagnetic parts – stator and rotor yoke (fig. 2a). In this case stator yoke is also used as an outer magnetic shield. The second is the scheme with only one ferromagnetic part ("ironless" scheme) – outer shield placed on the stator yoke (fig. 2b). Both constructions have non magnetic cores of stator and rotor windings.

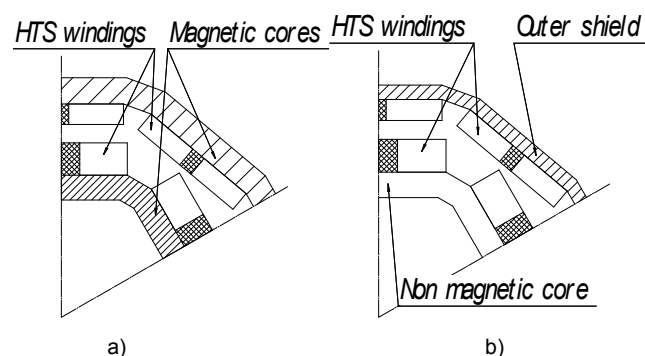

Fig. 2. Principal scheme of fully HTS machine with stator and rotor yoke (a) and with outer shield (b)

Comparison between two types of the machines

To compare two types of the machine we used equal initial parameters such as phase voltage $U=1000$ V and rotational speed $n=2500$ rpm. According to several research

[3, 7] critical current of HTS coil is lower than of HTS tape in self-field. Besides dimensions of HTS coil should be optimised to provide maximum magnetic flux and minimum magnetic inductivity in the area of the coil. In this research critical current of HTS tapes is $I_{sc}=65A$ for 4 mm tape taking into account that manufacturers always work on improvement of HTS tape properties. We calculated dimensions of active zone and main parameters of the machines with different output power: 1000 kW, 2000 kW, 3000 kW and 5000 kW. These power levels are very perspective for electric propulsion system of future aircraft. For example propulsion power of russian airplane SSJ-100 is 8 MW. On the other hand very interesting is distributed propulsion system with one or two generators and several motors. So 8 MW for propulsion system can be achieved by using 4 motors with output power 2 MW. The main goal was to achieve the maximum specific power for each machine. As a result we compared two types of the machines using data of 8 different machines.

On the first step we used analytical methodic listed in [8, 9, 10]. Methodologies are developed for two calculation schemes (fig. 3). As you can see active zone is divided to seven areas: I – rotor yoke, which is ferromagnetic for the first machine and nonmagnetic for the "ironless" machine; II – field winding; III – air gap; IV – stator winding; V – nonmagnetic gap between stator winding and magnetic shield; VI – outer magnetic shield (stator yoke); VII – outer area. In general armature winding is placed on the stator yoke and gap between them is equal to zero.

Methodology is based on Puasson's equations for vector magnetic potential $\Delta A = \mu_0 j$, where A – vector magnetic potential, j – current density, μ_0 – permeability of vacuum. Solving of this equation for different areas of the machine gives expressions for A . It allows to determine

EMF as $E_0 = \omega i_f M_{af}$, and inductive resistance as $X_a = \omega L$ where ω is angular frequency, i_f is field current,

$$M_{af} = \frac{1}{i_a R_{ai}} \int_{R_{ai}}^{R_{ao}} \Phi_f W_a d\rho$$

and armature winding, L is inductance of armature winding, W_a is number of turns in armature winding, R_{ao} and R_{ai} are outer and inner radius of armature winding, i_a is armature current, ρ is radial coordinate. M_{af} and L can be obtained using Puasson's equation for different areas with corresponding boundary conditions [$H_r]=0$, [$B_n]=0$ [9].

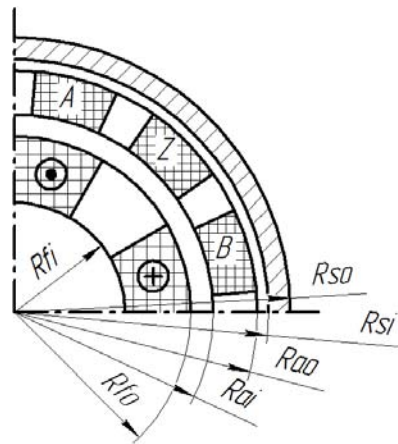

Fig. 3. Calculation scheme

Using Puasson's equations expressions for EMF and inductive resistances for two type of machines were obtained:

– for the machine with iron yokes:

$$(1) \quad E_0 = 4\sqrt{2}\pi K_a W_a f L_s G ((R_{fo}^{p+2} - R_{fi}^{p+2}) R_s^{-p} + \frac{K_\mu}{R_s^{2p} - R_{fi}^{2p} K_\mu} \left(R_{fi}^{p+2} R R_s^p \frac{2+p}{2-p} + R_{fo}^{p+2} R_{fi}^{2p} R_1 R_s^{-p} \right))$$

$$(2) \quad X_a = f \frac{L_s W_a^2 K_a^2 \mu_0 m}{p} T, \quad T = \left(R_{fo}^{2p} R_{fi}^{2p} + K_\mu \right) / \left(R_{fo}^{2p} R_{fi}^{2p} - K_\mu \right)$$

– for "ironless" machine:

$$(3) \quad E_0 = \frac{16 f \mu_0 w_f W_a L_s K_f K_a}{(R_{fo}^2 - R_{fi}^2)(R_{ao}^2 - R_{ai}^2)(2+p)p} \left[\frac{(R_{fo}^{2+p} - R_{fi}^{2+p})(R_{ao}^{2-p} - R_{ai}^{2-p})}{2-p} + \frac{K_{\mu i}}{R_{si}^{2p}} \frac{(R_{fo}^{2+p} - R_{fi}^{2+p})(R_{ao}^{2+p} - R_{ai}^{2+p})}{2+p} \right] \cos p\alpha$$

$$(4) \quad X_a = 4f \frac{m W_a^2 K_a^2 L_s}{p \left[1 - (R_{ai}/R_{ao})^2 \right]^2} \frac{\mu_0}{p+2} \left[1 - \frac{p+2}{p-2} \left(\frac{R_{ai}}{R_{ao}} \right)^4 + \frac{4}{p-2} \left(\frac{R_{ai}}{R_{ao}} \right)^{p+2} + \frac{2R_5 K_\mu R_7^2}{R_6(p+2) R_{si}^{2p} R_{ao}^4} \right]$$

where f – electrical frequency;

$$G = \left(2\mu_0 w_f i_f k_f \right) / \left(\pi (R_{fo}^2 - R_{fi}^2) p (p+2) \right); \quad k_f, \quad K_a - \text{winding coefficients of field and armature winding; } L_s - \text{active length; } w_f - \text{number of turns in field winding; } p - \text{number of pair poles; } K_\mu - \text{coefficient of outer shield: } K_\mu=1 \text{ for ferromagnetic shield, } K_\mu=-1 \text{ for diamagnetic shield; } m - \text{number of phases; } \mu_0 - \text{magnetic permeability of vacuum;}$$

$$R_1 = \left[1 - \left(R_{fi}/R_{fo} \right)^{p+2} \right], \quad R_2 = R_s/R_r,$$

$$R = \left[\left(R_{fo}/R_{fi} \right)^{-p+2} - 1 \right], \quad R_3 = R_r/R_{fi},$$

$$R_5 = (R_{so}/R_{si})^{2p} - 1, \quad R_6 = (R_{so}/R_{si})^{2p} - K_\mu^2,$$

$R_7 = R_{ao}^{2+p} - R_{ai}^{2+p}$ – construction coefficients; R_{fi} , R_{fo} – inner and outer radius of field winding; R_s – inner radius of stator.

Analytical expressions can be easily optimized, so we used them to choose dimensions of active zone of the machines and build their preliminary design.

On the next step we produced 2D finite-element modeling (FEM) using Elcut soft and sketches of the machines. The main goal was to clarify results of analytical calculation, to control saturation of ferromagnetic elements and to compare magnetic field density in the air gap. Fig. 4 shows distribution of magnetic field with background color indicating the magnitude of the flux density within two types of the machine with output power $P_2=1000$ kW for nonload condition.

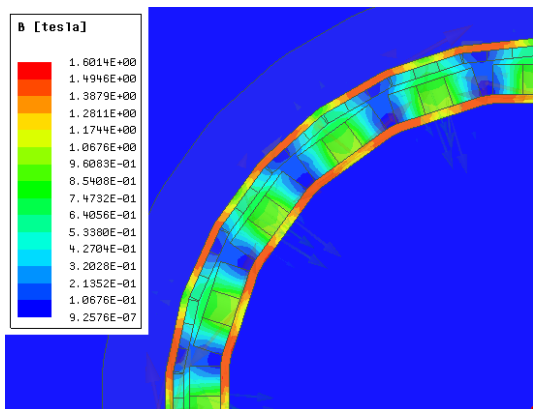

a)

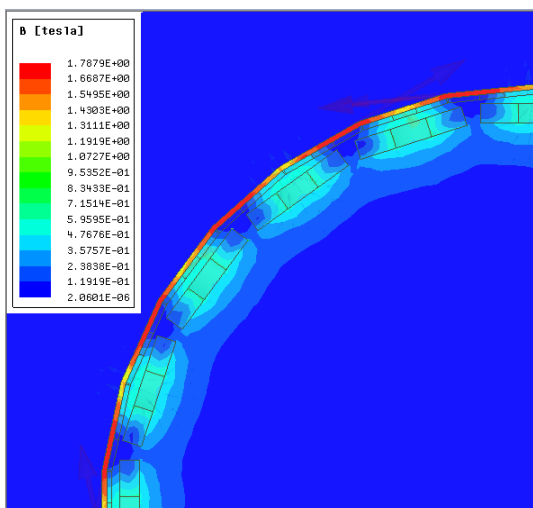

b)

Fig. 4. Magnetic field distribution for nonload condition: a) in the machine with stator and rotor magnetic yokes, b) in the "ironless" machine

The main parameters of the machines are listed in Table I. Dimensions and number of pair poles was chosen to provide the highest power density.

It is known that increasing of number of pair poles causes decreasing of magnetic flux line length and magnetomotive force of field winding [5]. Therefore stator magnetic yoke for multipole machine has lower height than for the machine with small number of poles. In this case the next rule will be actual: for infinity number of poles thickness of magnetic core will tend to null, and specific power will tend to infinity. But gradient of increasing of specific power for "ironless" machine will be higher because of absence of rotor's core. According to the Table I big number of pair poles for all machines was chosen. In fig. 5 magnetic field distribution for the 1000 kW machine with 2 yokes and low pole number is shown. Dimensions of such machine is

lower but specific power is lower due to higher height of magnetic core (see Table I).

On the other hand big pole number causes high electric frequency and increasing of losses: magnetic and AC losses in HTS windings. Moreover, big pair poles number is connected with technological difficulties.

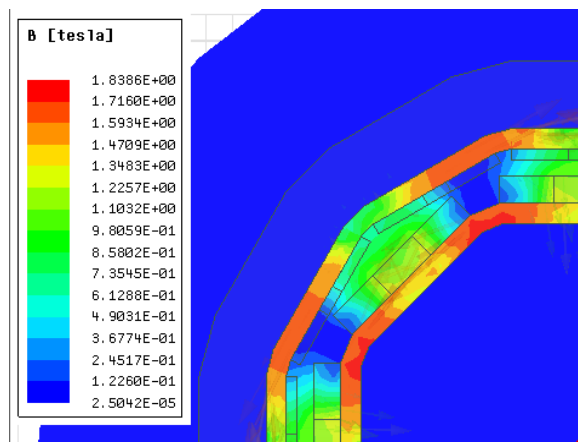

Fig. 5. Magnetic field of 1000 kW machine with low pole number

Value of magnetic inductance in the area of HTS windings is also very important due to high field dependency of critical current of modern HTS tapes. In this case "ironless" construction (fig. 4b) is more preferable because of lower value of magnetic inductance in the HTS windings area.

Fig 4 shows that magnetic induction in the active zone for the machine with magnetic yokes is higher. Conventional machines with permanent magnet could provide 1T in the air gap. But application of HTS armature winding helps to increase current loading up to 200 kA/m for machine with magnetic core and up to 100 kA/m for ironless machine. Besides permanent magnets have significant density.

It is known that application of saturated ferromagnetic elements in electrical machines is not rational. Decreasing of dimensions of the magnetic yokes will cause their saturation and decreasing of EMF. More than that magnetic field of the machine will not be illuminated. Fig. 4b shows distribution of magnetic field within "ironless" machine. According to fig. 2b and Table I thickness of outer ferromagnetic shield is smaller due to lower values of magnetic induction in the air gap. That is why dimensions of "ironless" machine is higher.

The result is values of specific power for two types of the machines. The weight of active elements include field and armature windings and magnetic cores. For traditional electric machine full weight can be approximately calculated as $M_{full}=2M_{active}$, where M_{full} – full weight of the machine including active and constructive elements, M_{active} – weight of active zone. This expression is actual for HTS machine too. It can be seen from the Table I that "ironless" machine can provide higher values of power density. In general it is connected with the absence of rotor's magnetic core. Beside this low height of outer shield also helps to achieve high power density.

Table I. Main parameters for the two types of the machines.

Name		HTS motor with two ferromagnetic yokes					"Ironless" HTS motor			
Power, kW	P_2	1000	1000	2000	3000	5000	1000	2000	3000	5000
Field winding inner radius, m	R_{fi}	0.25	0.18	0.28	0.28	0.37	0.32	0.37	0.4	0.4
Outer radius of the machine, m	R_{so}	0.29	0.22	0.32	0.33	0.42	0.348	0.404	0.435	0.446
Number of pair poles	p	10	4	9	9	10	10	10	10	10
Magnetic shield width, m	H_s	0.007	0.01	0.01	0.012	0.014	0.004	0.005	0.007	0.010
Active length, m	L_s	0.1	0.13	0.12	0.13	0.12	0.13	0.12	0.1	0.12
Electric frequency, Hz	f	416	166	375	375	416	416	416	416	416
Weight of active elements, kg	M	69	87	107	140	216	55	83	94	135
Specific power, kW/kg	$P_{\nu 0}$	14.4	11.5	18.6	21.4	23.1	18.2	24.1	31.9	37

Conclusion

Comparison between two types of the HTS machines based on theoretical investigations and FEM shows that "ironless" machine can provide higher specific power. Due to absence of rotor's magnetic core and lower height of outer shield. Main parameters for 9 machines were calculated. According to the result we expect that full mass of HTS machine with output power over 1000 kW will be higher than for conventional machine. It can be seen from the Table I that power densities for all machines are 14 kW/kg and more. So the full specific power will be more than 7 kW/kg and more. But for conventional machine this value is 5 kW/kg and lower. More than that specific power will be higher with increasing of transport current of HTS tapes. Of course, to enhance values of full specific power up to 20 kW/kg we need to develop new construction and design techniques for HTS machines.

According to comparison between two types of the machine "ironless" scheme can provide higher specific power. But it will be connected with high frequency and number of pair poles, big losses and high volume of cryogenic system. Decreasing of pole number will allow to decrease dimensions and losses of the machine but specific power will be lower too. Beside this multipole HTS motor will have very thin stator yoke which could not be used as a constructive element.

In genegall we every type of the machine can be usefull in specific application. More than that machine should be optimized with it's cryogenic system.

Very perspective is scheme where active zone of the machine will be built in external unit of aircraft, ship or windmill. High degree of integration will provide the higher power density of all system.

The reported study was funded by Russian Science Foundation (Project No. 17-19-01269).

Authors: dr Konstantin Kovalev, Moscow aviation institute, 125993, Moscow, Volokolamskoe shosse, 4, E-mail: klink@mail.ru; dr Nickolay Ivanov, Moscow aviation institute, 125993, Moscow, Volokolamskoe shosse, 4, E-mail: n.s.ivanov88@gmail.com; Irina Kobzeva, Moscow aviation institute, 125993, Moscow, Volokolamskoe shosse, 4, E-mail: irina.kobzeva.93@bk.ru;

Ekaterina Tulinova, Moscow aviation institute, 125993, Moscow, Volokolamskoe shosse, 4, E-mail: ketyl@mail.ru

REFERENCES

- [1] [http://www.siemens.com/press/en/feature/2015/corporate/2015-03-electromotor.php?content\[\]=Corp](http://www.siemens.com/press/en/feature/2015/corporate/2015-03-electromotor.php?content[]=Corp)
- [2] http://www.fujikura.co.jp/eng/products/newbusiness/superconductors/01/2052504_12808.html
- [3] D. Dezhin, R. Ilyasov, S. Kozub, K. Kovalev, L. Verzhbitsky, "Synchronous motor with HTS-2G wires", 11th European Conference on Applied Superconductivity (EUCAS2013) IOP Publishing. Journal of Physics: Conference Series 507 (2014) 032011 doi:10.1088/1742-6596/507/3/032011
- [4] Ronghai Qu, Yingzhen Liu, Jin Wang, Review of Superconducting Generator Topologies for Direct-Drive Wind Turbines, IEEE Transactions on Applied Superconductivity, 2013, vol. 23
- [5] Ivanov-Smolenskii A.V. Elektricheskie mashiny, t. 2 (Electrical machines, vol. 2). Moscow. Publ. of the Moscow Power Institute, 2006, 532 p. <http://www.superox.ru/products/0001.pdf>
- [6] Kozub, S., Bogdanov, I., Dezhin, D., Kashtanov, E., Kovalev, K. " HTS racetrack coils for electrical machines", 13th International Institute of Refrigeration Conference on Cryogenics, CRYOGENICS 2014. Refrigeration Science and Technology 2014, Pages 283-287
- [7] Kovalev L.K., Kovalev K.L., Koneyev S.M.-A. Elektricheskie mashiny i ustroystva na osnove massivnykh vysokotemperatimykh sverkhprovodnikov (Electrical machines and devices on the basis of bulk high-temperature superconductors). Moscow. Publ. «FIZMATLIT», 2010, 396
- [8] N. Ivanov, I. Kobzeva, K. Kovalev, V. Semehin, "Analytical methodic of calculation of fully HTS electric machine for aircraft". Innovations in energetic. Russian academy of science. Nauka, 2010, book 3 – Applied high temperature superconductivity – 2016, 142 pp.
- [10] Kovalev K., Kovalev L., Tulinova E., Ivanov N. "Methodic of calculation of magnetic field distribution in the active zone of synchronous generator with electromagnetic excitation. Electrichestvo, 2014, №5, pp. 12-17.
- [11] Kovalev, K.L., Verzhbitsky, L.G., Kozub, S.S., Penkin, V.T., Larionov, A.E., Modestov, K.A., Ivanov, N.S., Tulinova, E.E., Dubensky, A.A. Brushless superconducting synchronous generator with claw-shaped poles and permanent magnets. IEEE Transactions on Applied Superconductivity, Volume 26, Issue 3, April 2016, Article number 7405291, DOI: 10.1109/TASC.2016.2528995.