

## Comparative analysis of DC-DC inverters as a means of protection against nanoseconds impulses

**Abstract.** The article presents examples of DC-DC inverter designs, especially their voltage characteristics impaired by nanosecond types EFT/Burst pulses. Numerical simulations and laboratory tests have been performed. The results obtained were compared and conclusions were drawn.

**Streszczenie.** Artykuł przedstawia przykładowe wykonania przetwornic DC-DC, w szczególności ich charakterystyki napięciowe w trakcie zaburzenia impulsami typu EFT/Burst o nanosekundowych czasach. Przeprowadzone i opisane zostały symulacje numeryczne i laboratoryjne testy porównawcze. Uzyskane wyniki zostały opisane i porównane, a na końcu przedstawiono wyciągnięte wnioski. (Analiza porównawcza przetwornic DC-DC jako środka ochrony przed nanosekundowymi impulsami zaburzającymi).

**Słowa kluczowe:** przetwornice DC-DC, impulsy NEMP, impulsy nanosekundowe, symulacje numeryczne.

**Keywords:** dc-dc inverter, NEMP impulses, nanoseconds pulses, numerical simulations.

### Introduction

At present, many electronic devices, in order to perform their job properly, must be powered in a stable manner. For many years, power supplies were built on the basis of transformers that reduced the voltage from the 230 VAC power level to slightly higher than the required level (Figure 1). In addition, the conversion from AC to DC was performed, and this task was most often implemented by a set of semiconductor diodes connected in the Graetz bridge. The straightened voltage was still to be smoothed out, which was achieved by the parallel charging of the electrolytic capacitor. This traditional configuration of a power supply, also called a linear power supply, caused high energy losses, which translates into a relatively low efficiency of 40-60%. Most of this energy was lost in the transformer in the generated magnetic field and heat. In addition, such constructions were characterized by large dimensions and often the need to install additional cooling elements. Moreover, when working idle without load, the power supply also consumes more power - more or less depending on transformer parameters. Due to technological advances, the increasing demands for power supply efficiency and the increasing efficiency of the receivers, the power supply design has changed significantly in the direction of power supplies.

### Power suppliers

The principle of operation of the impulse power supply (often called the converter) is somewhat similar to a linear power supply, but the biggest difference is the process of "processing" the voltage.

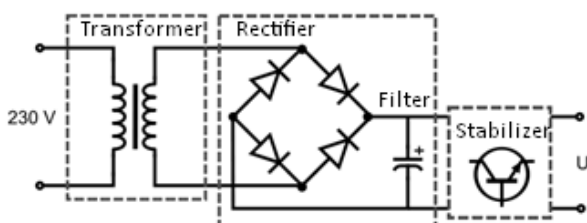

Fig. 1 Linear power supply diagram.

In the first place, it is rectified with semiconductor diodes (e.g. Graetz bridge) and then smoothed with a capacitor. In some cases, a passive filter (e.g. a gland seal) is also used here to reduce the emission of harmonics to the mains. The straightened voltage is then smoothed and filtered by the LC circuits to be fed into the primary transformer of the RF

transformer in such form. Unlike a transformer from a linear power supply that operates at 50 Hz, it operates at frequencies from several to several hundred kilohertz. Thanks to such a treatment, i.e. the lack of alternating voltage and high frequency, the efficiency of the transformer is noticeably increased and its size decreases. Unfortunately, it is often necessary to re-apply the filtering and smoothing systems on the secondary side, because the transformer can effectuate voltage deformation through its characteristics. Information about the level of the output voltage through the feedback line can be given to a system that regulates the level of the control signal of the transformer to keep the voltage level constant. The general scheme of this type of power supply is shown in Figure 2, and more detailed will be presented later in this article.

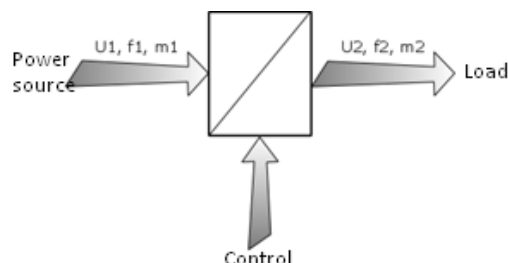

Fig. 2 Block diagram of impulse type power supply.

Depending on what voltage is converted there are marked out AC-AC, AC-DC, DC-AC and DC-DC converters [1]. Due to the direction of the research for pending grant, DC-DC converters have been selected. These are systems using battery power, and their task is to match the voltage and current sources to the burden while retaining the features of energy efficiency and resistance to nanosecond impulses.

### Simulations tests

#### General description.

Two DC-DC converters with different characteristics have been tested for modelling:

- non-isolated BUCK type (indicated as P1),
- isolated FORWARD type (indicated as P2).

The BUCK (P1) converter is a voltage-reducing converter with no galvanic separation between the input and the output. It converts DC to DC with an adjustable average value less than or equal to the input voltage. A schematic of this type converter is shown in Fig. 3.

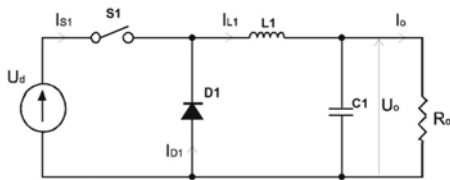

Fig. 3 Diagram of a BUCK converter.

The FORWARD converter used in the simulations was an isolated version (galvanic isolated input and output), asymmetric, single-pass with one key. Its diagram is shown in Fig.4.

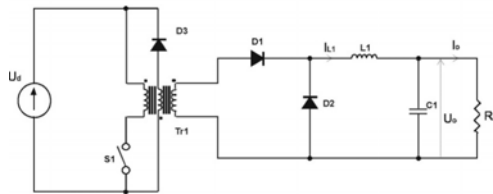

Fig. 4 Diagram of a FORWARD converter.

In one-key converters, the power is taken from the source and transmitted through the transformer to the burden during the conduction of the wrench.

On both schemes the keys were marked with S1, the voltage rectification function was performed by semiconductor diodes marked D1 - D3, and the smoothing of the voltage waveform was obtained by using the LC components. The burden on the power supply was R0. For both modelled systems, the following disturbance configurations are provided:

- work without disturbance,
- clock line disturbed (timing the wrench),
- load side disturbed,
- the voltage source disturbed.

Modelling was done in MATLAB / SIMULINK environment. Both modelled converters have the following operating conditions:

- wrench frequency  $f_p=20$  kHz,
- filling the key pulse  $d_p=0,25$ ,
- input voltage  $U_d=50$  V,
- inductance of the filter  $L_1=50$   $\mu$ H,
- filter capacity  $C_1=25$   $\mu$ F,
- load resistance  $R_0=10$   $\Omega$ ,
- frequency of disturbing signal  $f_2=1$  GHz,
- filling the impulses of the disturbing signal  $d_2=0,5$ .

#### Simulation of P1 converter.

The P1 converter model is shown in Fig. 5.

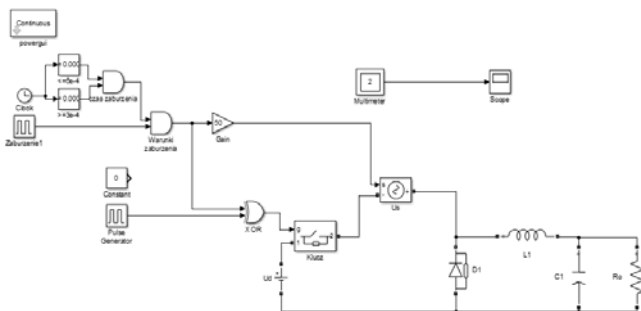

Fig. 5 Numerical model of BUCK type converter

According to the above scheme, the disturbing signal was driven by the AND gate system to determine the time

range in which it will be applied to the operating signal. Exemplary results are shown in Fig. 6 - Fig. 9.

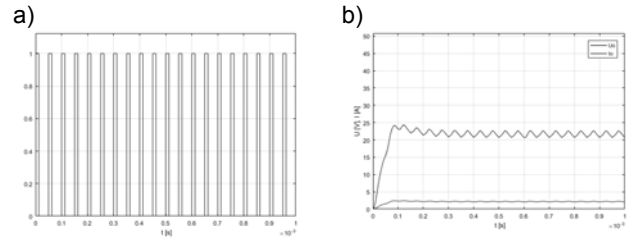

Fig. 6 Converter without disturbances: a) clock signal, b) output voltage.

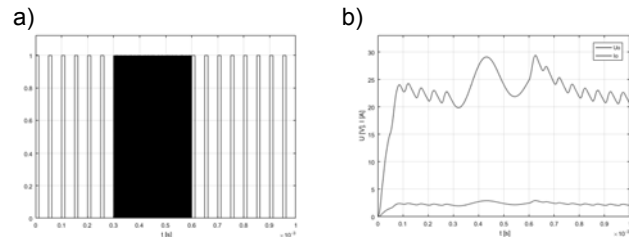

Fig. 7 Converter with clock cycle disturbances: a) clock signal, b) output voltage.

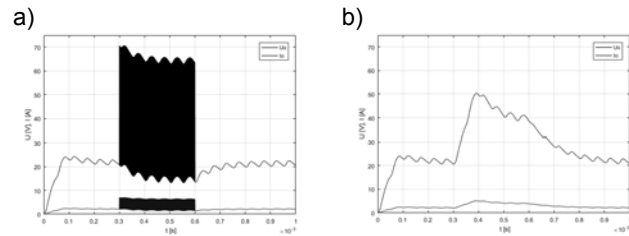

Fig. 8 Converter with disturbances: a) before load  $R_0$ , b) before  $L_1C_1$  filter.

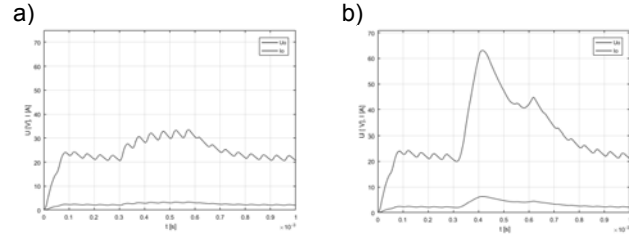

Fig. 9 Converter with disturbances: a) in front of diode D, b) in front of diode D and in clock line.

#### Simulation of the P2 converter.

The model of converter P2 used in the simulations is shown in Fig. 10.

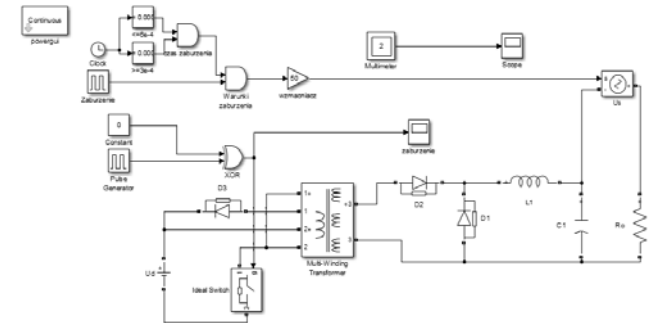

Fig. 10 Numerical model of FORWARD converter.

The following illustrations are showing exemplary results.

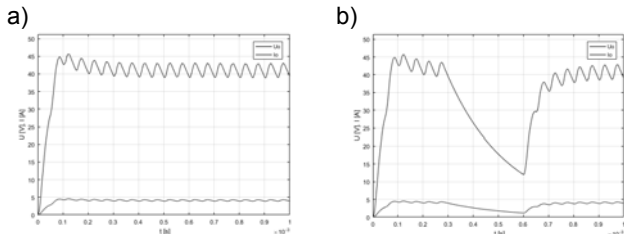

Fig. 11 Output voltage of FORWARD converter: a) without disturbances, b) with disturbances in the clock line.

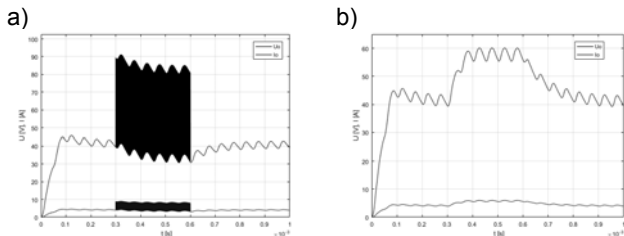

Fig. 12 Output voltage of FORWARD converter: a) with load disturbances R0, b) with L1C1 filter.

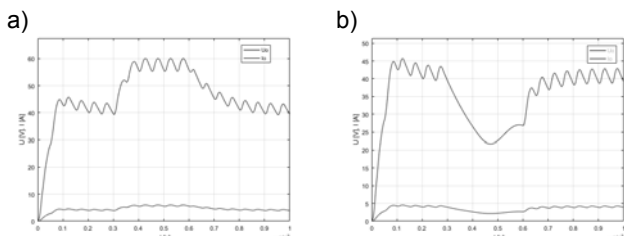

Fig. 13 Output voltage of FORWARD converter: a) with diode  $D_2$  disturbances, b) with diode  $D_2$  disturbance and clock path.

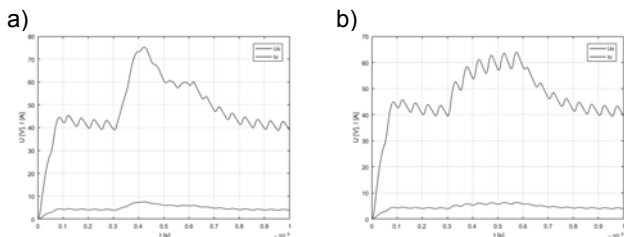

Fig. 14 Output voltage of FORWARD converter with transformer disturbances in: a) winding 1, b) winding 2.

### Laboratory tests

#### General description.

A series of laboratory tests has also been carried out to verify the simulation results. It included a number of different types of DC-DC converters, of which the following were chosen for the purposes of this article:

- universal, stabiliser replacement 7805,
- lowering the tension,
- isolated.

Due to their compact design, not all simulated configurations could be reproduced, hence the test program was slightly shorter and included:

- observation of work under rated conditions,
- disturbance in the circuit of the power source,
- disturbance in the load circuit.

The BEST / EMC generator in the EFT / Burst generation mode was used as the source of the nanosecond disturbances [2]. The impulse parameters were as follows:

- positive polarisation,
- number of pulses in series – 75 (which corresponds to 75 ms duration of the series),
- frequency of repetition of impulses – 1 kHz,
- frequency of repetition of pulse series – 300 ms.

The power source for the converters tested was a stabilized power supply, and time observations were made using the LeCroy WS3074 and Tektronix TDS2012B oscilloscopes. The entire station is shown in Fig. 15



Fig. 15 View of the test stand.

#### Universal converter.

This converter was a low power universal for replacement applications with the 7805 stabilizer. The input voltage was set at 12V and the output was 5V. The manufacturer's declared efficiency is 65%. Its picture is shown in Fig. 16.

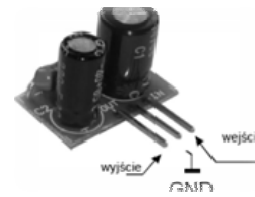

Fig. 16 Universal converter.

Sample results are shown in Fig. 17 and Fig. 18. During the study of both the input sides (oscilloscope channel 1) and the output channel (oscilloscope channel 2) were observed.

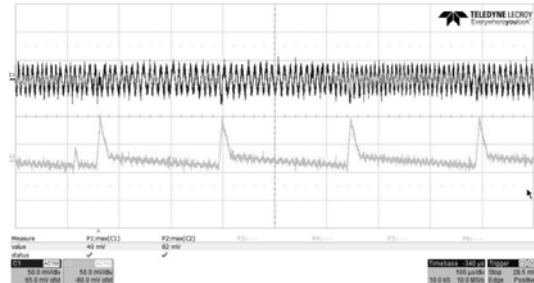

Fig. 17 Input and output voltages of the universal converter at a load current of 25 mA.

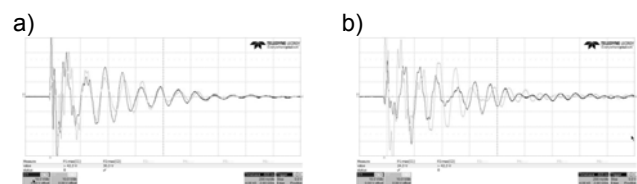

Fig. 18 Universal converter output voltage: a) IN + disturbances, b) OUT + disturbances.

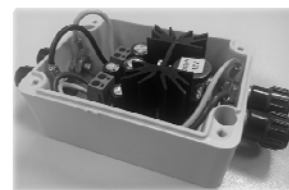

Fig. 19 Voltage reduction converter.

### Voltage reduction converter.

The tested inverter was characterized by 60V input voltage and 12 V output voltage. Nominal load current is 3A and efficiency is 85%. A photograph of the examined system is shown in Fig. 19.

Test results of the converter without disturbances and with the interfering signal are shown in Figures 20 and 21.

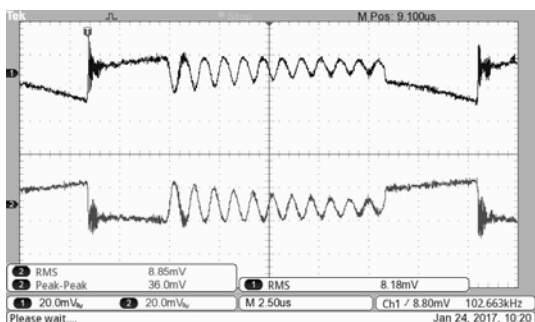

Fig. 20 Voltage reduction converter - work without disturbance.

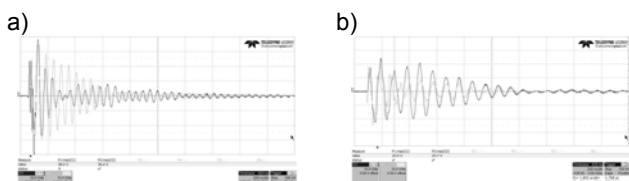

Fig. 21 Voltage reduction converter output voltage: a) IN + disturbances, b) OUT + disturbances.

### Isolated converter.

This converter has a galvanic isolation between input and output and efficiency of 80%. The input voltage is 12V, and the output voltage is 9V. The item image is shown in Fig. 22. The obtained results are shown in Fig. 23 and Fig. 24.

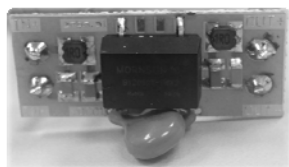

Fig. 22 Converter with isolated output.

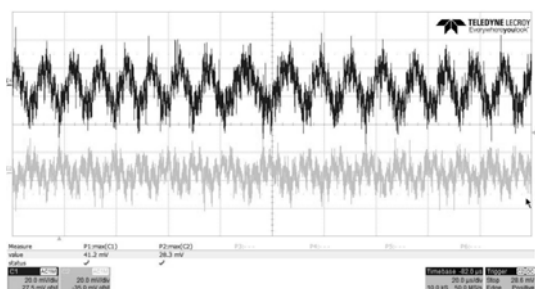

Fig. 23 Converter with isolated output - without disturbances.

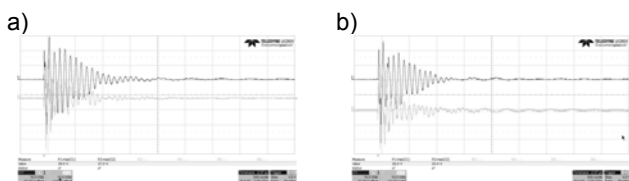

Fig. 24 Converter output voltage with isolated output: a) IN + disturbances, b) OUT + disturbances.

### Oscillation juxtaposition.

As a result of series of observations and numerous results, a juxtaposition of the measured oscillations generated by the disturbance signals was developed.

	IN+		OUT+	
	U <sub>in</sub>	U <sub>out</sub>	U <sub>in</sub>	U <sub>out</sub>
DC01A	>85V	59V	56V	>85V
DCU1-24V	54V	53V	38V	51V
DCU1-48V	63V	60V	39V	45V
DC3HV-12V	81V	65V	47V	53V
DC3HV-24V	49V	38V	39V	32V
iDC01	59V	61V	57V	50V

Fig. 25 Juxtaposition of measured oscillations.

### Summary and conclusions

On the basis of the conducted studies it can be concluded that the disturbances of this kind are transmitted in both directions: from the input to the output and the output to the input of the converter. This also applies to the tested converter. Due to the integrated nature of the inverters there was no possibility of coupling the disturbance to the clock. As well as accurate reproduction of the simulated test systems. Newralgic due to the induction of disturbances with nanosecond times are both DC power supply and load side power lines and a clock line. In most modern inverters, the clock line is integrated, minimizing the impact of field disturbances. Considering the nature of the converters (eg powering the electronics), it is unlikely to expect such large disturbances due to the use of field interference and the large distance from its source. The proposed protection measure may be a low-pass low-pass filter installed at the input and output of the converter as well as at the input of the electronics. Its variants can also be a varistor providing protection against potential surges. Protection against electromagnetic fields is described in another article [3].

**Authors:** dr inż. Konrad Sobolewski, Politechnika Warszawska, Instytut Elektrotechniki Teoretycznej i Systemów Informacyjno-Pomiarowych, ul. Koszykowa 75, 00-662 Warszawa, e-mail: Konrad.Sobolewski@ee.pw.edu.pl; dr inż. Michał Wojciechowski, Politechnika Warszawska, Instytut Elektrotechniki Teoretycznej i Systemów Informacyjno-Pomiarowych, ul. Koszykowa 75, 00-662 Warszawa, e-mail: Michal.Wojciechowski@ee.pw.edu.pl.

### REFERENCES

- [1] S. Kuta, Elementy i układy elektroniczne, AGH 2000
- [2] Norma PN-EN 61000-4-4, Kompatybilność elektromagnetyczna (EMC) - Część 4-4: Metody badań i pomiarów - Badanie odporności na serie szybkich elektrycznych stanów przejściowych.
- [3] K. Sobolewski, K. Dydek, Composite panels as electromagnetic field shields, Computational Problems of Electrical Engineering, CPEE 2016, Sandomierz
- [4] N. Mohan, T.M. Undeland, W.P. Robbins, Power electronics: converters, applications and design (Wiley, 1995, 2nd Edn.)
- [5] C. Attaianesi, V. Nardi, G. Tomasso, Electromagnetic self-compatibility of power converters, 2004 35th Annual IEEE Power Electronics Specialists Conference, Aachen, Germany
- [6] K.R.A Britto, RVimala, R. Dhanasekaran, B. Saranya, Modelling of conducted EMI in flyback switching power converters, IEEE, Electronics and Control Engineering (ICONRAEeCE), Page(s): 377- 383, 2011
- [7] F. Zare, EMC and Modern Power Electronic Systems, IEEE EMC Symposium, 2008