

The transient analysis of the hydrogenerator of Nurek HPP subject to automatic excitation control action

Abstract. At present time, the task of studying the operating conditions of synchronous generators operating in parallel with the power system taking into account the introduction of new capacities in the system and increasing their stability provokes interest for research. An effective mean of the stability of power plants, as part of the power system, is automatic excitation control. The simulation environment MATLAB / Simulink is widely used in the calculation and analysis of normal steady-state and transient conditions of electrical systems. The article presents the results of the study and the comparison of operating parameters on the example of the Nurek hydropower plant. The results obtained will be useful in studying the use of modern types of AEC in the excitation system of the generators of Nurek HPP.

Streszczenie. Skutecznym środkiem stabilności elektrowni, jako części systemu elektroenergetycznego, jest automatyczna kontrola wzbudzenia. Środowisko symulacyjne MATLAB / Simulink jest szeroko stosowane w obliczeniach i analizach normalnych stanów ustalonych i stanów nieustalonych układów elektrycznych. W artykule przedstawiono wyniki badań i porównanie parametrów eksploatacyjnych na przykładzie elektrowni wodnej Nurek. Uzyskane wyniki będą przydatne w badaniu wykorzystania nowoczesnych typów AEC w układzie wzbudzenia generatorów Nurek HPP. Analiza stanów przejściowych generatora z automatycznym sterowaniem wzbudzenia na przykładzie hydroelektrowni Nurek

Keywords: synchronous generator, automatic excitation control of a strong action (AEC-SA), transients, short circuit.

Słowa kluczowe: generator synchroniczny, automatyczna kontrola wzbudzenia silnego działania (AEC-SA), stany nieustalone, zwarcie.

Introduction

In the Republic of Tajikistan (RT) in order to increase the level of population's welfare due to an economic growth, accompanied by the increasing of generating capacities through a construction of new powerful power plants, such as Rogun HPP with a capacity of 3,600 MW. In this case, the power flow through the transmission lines is increased, as well as the levels of short-circuit currents in the high-voltage nodes of the electric power system of the Republic of Tajikistan is also increased. These factors affect to the maintaining of the power system stability. Changing the parameters of the conditions to certain limits - determine the stability of power system which in turn depend on the automation system.

The emergency control automatic system provides automatic control or regulation in emergency cases mainly. Therefore, it includes an equipment for automatic excitation control, providing of the increasing stability and parallel operation of generators on a common network [1]. The main purpose of AEC is a rapid and significant increase (forcing) of the excitation of generators to the highest value, which provide and allow the excitation system under violations of the normal condition, accompanied by a voltage drop and current increase [2].

Purpose of research

The purpose of this study is to determine an effect of AEC on the values of currents in the rotor's excitation winding of hydrogenerator under three-phase short circuit on the transmission line.

Simulation of the calculated model

In this regard, a calculated model was developed to determine the effect of AEC to the current values in the excitation winding of the hydrogenerator rotor. The Matlab software package was chosen to develop a calculated model. The Matlab/ Simulink library is a set of visual blocks by the help of which it is possible to conduct practically a study of any complexity for electrical circuits. The ability to customize the parameters exists for all blocks, reflected in the margins of the settings window of the selected block.

The synchronous generator was simulated by a three-phase element "Synchronous Machine pu Standard" which

allows to carry out in-depth analysis of transients taking into account the influence of damper windings obtained by preliminary transformations by the well-known system of Park-Gorev equations, supplemented by the rotor motion equation [3]. The equivalent circuit of the model is represented in the rotor reference frame (qd frame). All rotor parameters and electrical quantities are viewed from the stator. They are identified by primed variables. The subscripts are:

d,q — d- and q-axis quantity

R,s — Rotor and stator quantity

l,m — Leakage and magnetizing inductance

f,k — Field and damper winding quantity

The relevant equations are:

$$V_d = -i_d R_s - \omega \psi_q + \frac{d\psi_d}{dt}$$

$$V_q = -i_q R_s - \omega \psi_d + \frac{d\psi_q}{dt}$$

$$V_0 = -i_0 R_0 + \frac{d\psi_0}{dt}$$

$$V_{fd} = \frac{d\psi_{fd}}{dt} + R_{fd} i_{fd}$$

$$0 = \frac{d\psi_{kd}}{dt} + R_{kd} i_{kd}$$

$$0 = \frac{d\psi_{kq1}}{dt} + R_{kq1} i_{kq1}$$

$$0 = \frac{d\psi_{kq2}}{dt} + R_{kq2} i_{kq2}$$

$$\begin{bmatrix} \psi_d \\ \psi_{kd} \\ \psi_{fd} \\ \psi_q \\ \psi_{kq1} \\ \psi_{kq2} \end{bmatrix} = \begin{bmatrix} L_{md} + L_l & L_{md} & L_{md} & L_{md} & 0 & 0 \\ L_{md} & L_{lkd} + L_{f1d} + L_{md} & L_{f1d} + L_{md} & 0 & 0 & 0 \\ L_{md} & L_{f1d} + L_{md} & L_{lfd} + L_{f1d} + L_{md} & 0 & 0 & 0 \\ L_{mq} + L_l & L_{mq} & L_{mq} & L_{mq} & 0 & 0 \\ L_{mq} & L_{mq} + L_{kq1} & L_{mq} & 0 & 0 & 0 \\ L_{mq} & L_{mq} & L_{mq} & L_{mq} + L_{kq2} & 0 & 0 \end{bmatrix} \begin{bmatrix} -i_d \\ i_{kd} \\ i_{fd} \\ -i_q \\ i_{kq1} \\ i_{kq2} \end{bmatrix}$$

The electrical model of the machine is shown in figure 1.

To the input of which the variables Pm (power on the rotor shaft) and Uf (excitation voltage) are fed by the adjustable turbine and the excitation system, depending on the operating conditions of the synchronous generator. The auxiliaries of the generator are fulfilled by the element Three-Phase Parallel RLC Load, which represents an active load equal to 3 MW.

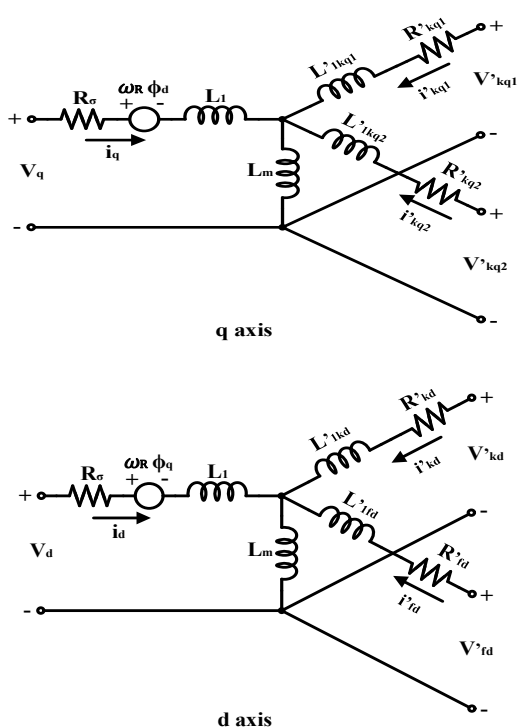

Fig.1. Electrical model of synchronous machine

The element “Three-Phase Transformer” was chosen as a model of a step-up double-winding transformer. The double-circuit power line (OHL1 and OHL2) is shown with the help of parallel-connected elements “Three-Phase PI Section Line”. The element “Three-Phase Source” is used as a power system, which represents a three-phase power source with a constant EMF (electromotive force). The

model also contains the elements of the “Hydraulic Turbine and Governor”, the “Three-Phase Breaker” and the “Three-Phase Fault” producing an artificial short circuit. Measurement of operational parameters is displayed by the “Measuring Instruments” subsystem gave in figure 2.

Simulation in Matlab/Simulink was carried out using the powergui block (subsections of Load Flow and Machine Initialization), which calculate the steady-state network and determine the initial operating parameters of the synchronous generator.

In accordance with [2], when studying electromagnetic transients in electric power systems, it is allowed to neglect the saturation of magnetic systems of electrical machines, the magnetizing current of transformers, the transverse capacitance of overhead transmission lines, including 330 to 500 kV lines.

In this paper, using the example of the Nurek HPP unit, the task was to determine the values of currents in the rotor winding under three-phase short circuit on the transmission line with its further disconnection. Three combined power units (for a voltage of 500 kV) and three power units (for a voltage of 220 kV) of a BFCBΦ 940 / 235-30 series synchronous generator with a capacity of 335 MW (394 MVA) each were installed at the Nurek HPP. In this regard, for the beginning, the value of currents at a three-phase short circuit of one synchronous generator operating on the network through a step-up transformer TL -400000 / 500-73

Y1 and double-circuit 500 kV line to the equivalent power system were considered. The result of calculating the three-phase short-circuit current on a 500 kV transmission line is 3.716 kA (the short-circuit current value in the case of a single generator), that confirmed by the three-phase short-circuit current given in [4].

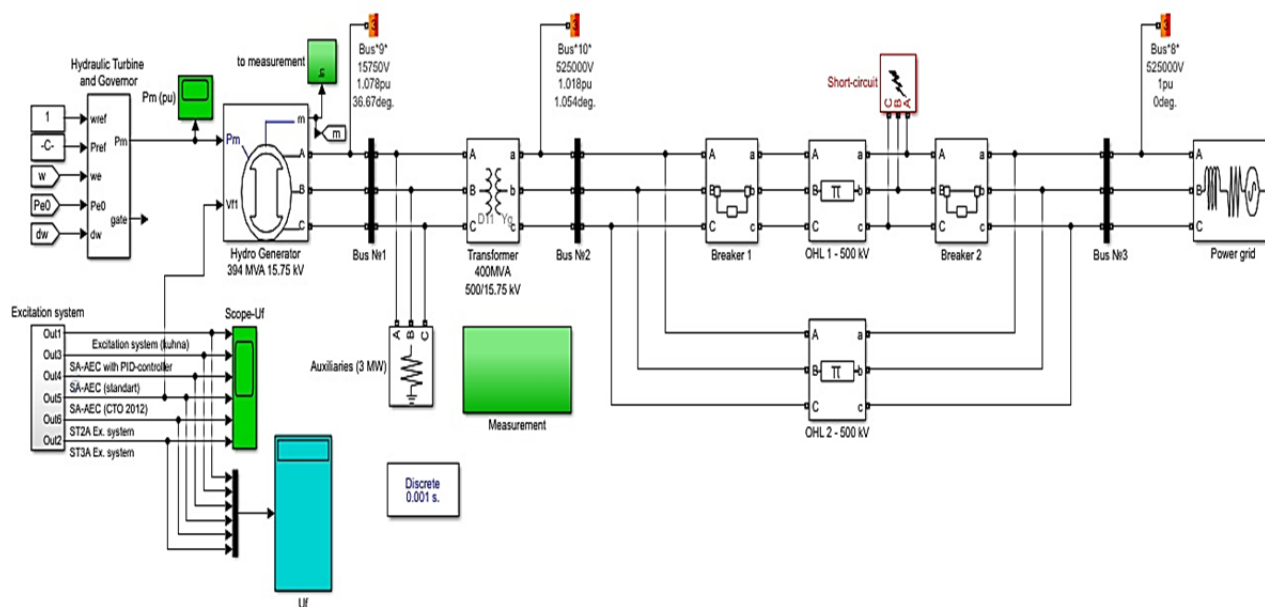

Fig.2. Calculated model of the electrical network in the Matlab/Simulink environment

Mathematical models of excitation system with AEC-SA

AEC-SA is a multi-channel device that provides the maintenance of the required voltage level at a given point in the system, forcing excitation in emergency conditions, damping oscillations at small and finite disturbances, limiting the minimum and maximum rotor currents, and also performing a number of other functions.

Regulation of excitation has a significant impact to the operating conditions of generators during transients, in connection with this, a mathematical model of the excitation system with AEC-SA was created in accordance with the model and recommendations [5-6]. The excitation system of Nurek HPPs hydrogenerator is made according to the self-excitation scheme with a series-wired boost transformer

and AEC-SA. The regulator of strong action has in the regulation law, in addition to the deviation value of the voltage and the reactive current of the stator, the following parameters: the derivative of the generator voltage, the derivative of the rotor current, frequency deviation and derivative of frequency. The model of the excitation system is shown in Figure 3.

The parameters of the transient process during a short circuit depend on the degree of remoteness of the short-circuit point from the generator buses, are accompanied by

an abrupt change and consequently by a sharp increase of currents. To facilitate the study, all calculations of the short-circuit have been made in relative units.

In the event of a short circuit, the current in the excitation winding increases due to the action of the AEC-SA, therefore, any change in the rotor is accompanied by changes in the stator [7-8].

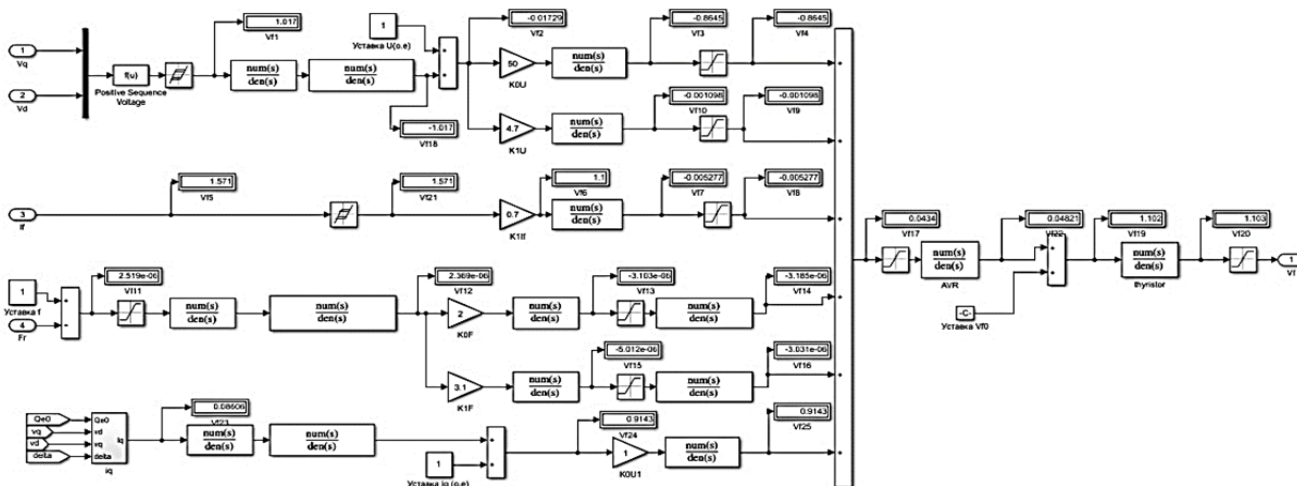

Fig.3. Synchronous generator mathematical models of excitation system with AEC-SA

Simulation Results

The oscillograms of the rotor current under a sudden three-phase short circuit with duration of 0.2 s is provided in Figure 4.

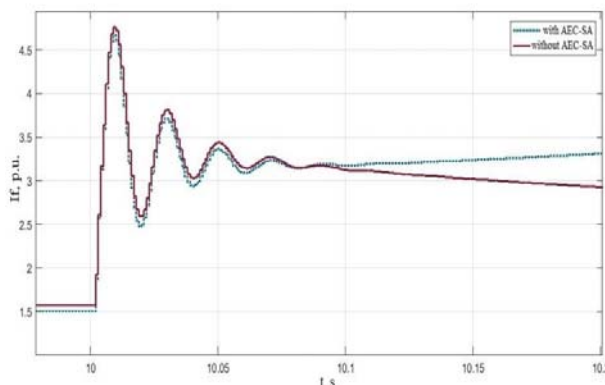

Fig.4. Curves of current changes in the excitation winding

Simultaneously with the disconnection of the short circuit, one circuit of the damaged section is disconnected.

From Figure 4, it can be seen that the process of increase and attenuation of currents during the transient process with increasing distance of the short-circuit point from the generator bus, occurs slowly. In the initial stage of the transient process with a short-circuit, the action of the AEC-SA is not noticeable, such a process takes place in the excitation winding, where the action of the AEC-SA gradually increases the excitation current, that is, the change in I_f lags behind the changes in U_f due to the large inductance of the excitation winding. Then for some time it appears more and more intensively, tending to

maintain the voltage on the generator bus, due to increase of the excitation voltage.

The change of the excitation voltage under above conditions is shown in Figure 5.

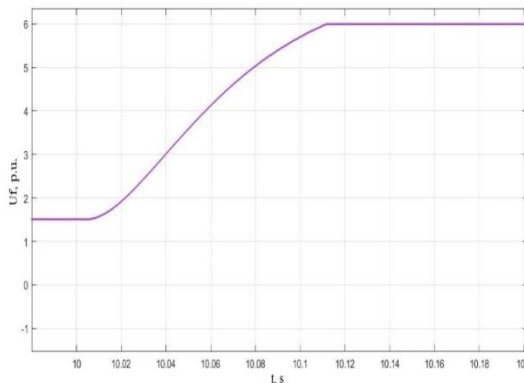

Fig.5. Curve of excitation voltage change at the moment of short circuit.

According to the Figure 6, a voltage reduction under the short-circuit U_g leads to the increasing of difference U_0-U_g , and consequently, to increasing of the excitation voltage U_f (Figure 5).

The amplitude values of the voltage on the generator bus are shown in Figure 6.

Analyzing the value of the voltage on the generator bus during a short-circuit, you can see that under AEC-SA it remains almost unchanged at a certain value, and without AEC-SA begins to decrease. Supporting of a normal voltage level on the generator bus leads to reducing of the active power shedding.

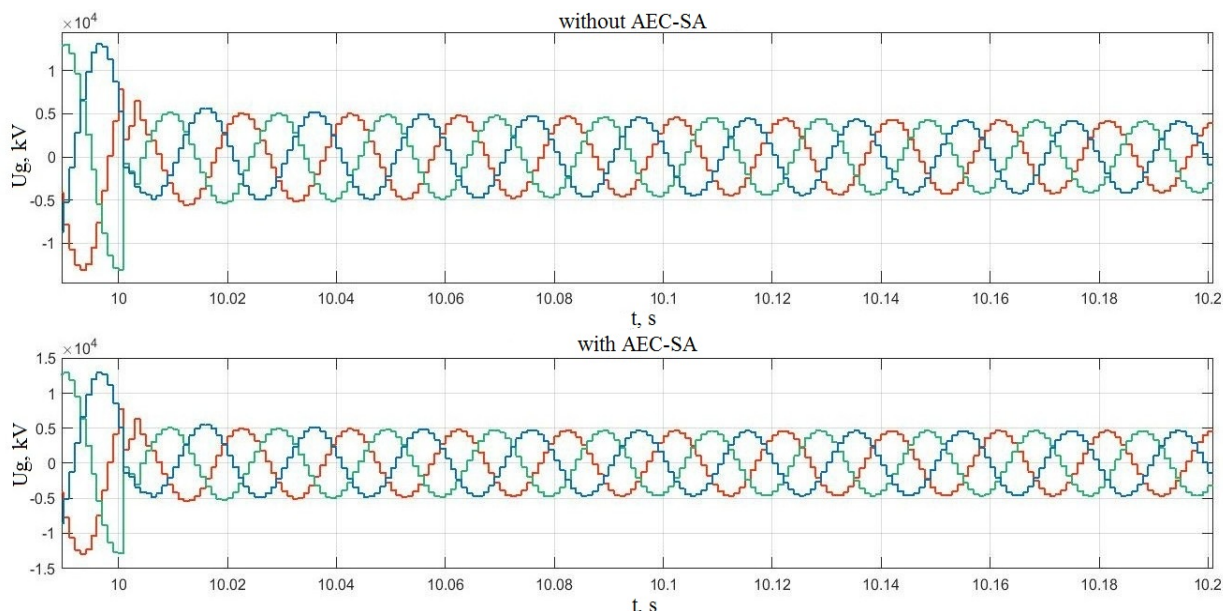

Fig.5. The amplitude values of the voltage on the generator bus

Conclusion

Depending on the distance of the short circuit location of busbars from the power plant, the process of increasing and damping the excitation currents during the transition is slow.

In the presence of AEC-SA, the attenuation of free currents arising in the field winding during a three-phase short circuit compensated by voltage increasing from the action of AEC-SA. Maintaining the voltage level on the generator busbar with AEC-SA during short circuit at a certain value reduces the discharge of electric power.

Usage the AEC-SA model, it was shown that optimal coefficients can be found on the stabilization channels, which provide acceptable damping indicators for various damage on the transmission line.

Acknowledgments

The reported study was funded by RFBR, project number 19-38-90204.

Authors: post-graduate student Murodbek Kholnazarovich Safaraliev, Department of Automated Electrical Systems, Ural Federal University, 19, Mira Street, Ekaterinburg, 620002, Russian Federation, e-mail: murodbek_03@mail.ru; Representative of Andritz Hydro GmbH in the Republic of Tajikistan Khusrav Nazir Rasulzoda, Khusrav.rasulzoda@andritz.com; Representative of Andritz Hydro GmbH in the Republic of Tajikistan Rajabbek Ayombekovich Otashbekov, st. Bokhtar 37/1, Dushanbe, 734025, Republic of Tajikistan, Rajabbek.Otashbekov@andritz.com; PhD Jamshed Bobomurodovich Rahimov, Department of power plants, Tajik Technical University, 10, Acad. Rajabovich Street, Dushanbe, 730092, Republic of Tajikistan, jam-rahimov@mail.ru; PhD Dmitry Anatolievich Pavlyuchenko, Department of industrial power systems, Novosibirsk State Technical University, 20, Karl Marx Street, Novosibirsk, 630073, Russian Federation, pavlyuchenko@corp.nstu.ru;

REFERENCES

- [1] Shchedrin V.A. Elektromagnitnyye perekhodnyye protsessy v elektricheskikh sistemakh. Uchebnoye posobiye, *Izdatel'stvo Chuvashskogo universiteta*, Cheboksary. – 2007. – 416 p.
- [2] Glebov I.A. Elektromagnitnyye protsessy sistem vozbuzhdeniya sinkhronnykh mash. *Nauka. Leningr. otd-niye.* - 1987. 344 p.
- [3] Kundur P., *Power System Stability and Control*, McGraw-Hill, 1994
- [4] Rakhimov, J.B. Conformity assessment of the breaking capacity of circuit breakers for short circuit currents and transient recovery voltages in the power system of the Republic of Tajikistan: disc. tech. Sciences: 05.14.02. - M., 2018. -160 s.
- [5] Rasulzoda Kh. N., Shchedrin V.A. Issledovaniye perekhodnykh protsessov v obmotke rotora gidrogeneratora pri korotkikh zamykaniyakh v sisteme s uchedom deystviya avtomaticheskogo regulirovaniya vozbuzhdeniya. *Vestnik Chuvashskogo universiteta.* - 2019. -№ 1. - p. 112-118.
- [6] Kokin S.E., Safaraliev M.Kh., Rasulzoda Kh.N. Otashbekov R.A., Rahimov J.B., Sultonov Sh.M. Transient Stability Analysis in Rotor Winding of Hydrogenerator at Various Short Circuit Values in Power Grid in Consideration with AEC // *XVI-th International Conference on Electrical Machines, Drives and Power Systems ELMA*, June 6-8. 2019. Varna, Bulgaria. 4 p.
- [7] Tashchilin V., Chusovitin P., Shabalin G., Pazderin A. Pss tuning method based on power system model identification using pmu // *IEEE PES Innovative Smart Grid Technologies Conference Europe Cep. "2014 IEEE PES Innovative Smart Grid Technologies Conference Europe, ISGT-Europe 2014"* . - ISGT-EUROPE 2014 Istanbul: IEEE Computer Society, 2015. - p. 7028817.
- [8] Excitation System Models For Power System Stability Studies. *IEEE Trans., PAS-100* (1981), No. 2, 494-50.
- [9] Kanálik M., Margitová A., Kolcun M. Modeling of Synchronous Machines Including Voltage Regulation // *Przeglad Elektrotechniczny*, 7/2019, p. 125-132.