

Fully spectrum-sliced four-wave mixing wavelength conversion in a Semiconductor Optical Amplifier

Abstract. *The semiconductor optical amplifier device has garnered significant interest in recent years, both in academic and commercial circles. This diminutive yet remarkable device has been the focus of numerous academic papers, primarily due to its multifunctionality and gain capabilities. In this study, four-wave mixing (FWM) wavelength conversion was successfully achieved in an SOA using a single, cost-effective spectrum-sliced incoherent source for both pump and probe. This concept holds substantial potential for application in future cost-effective, fully spectrum-sliced systems.*

Streszczenie. *Półprzewodnikowe wzmacniacze optyczne cieszą się w ostatnich latach dużym zainteresowaniem, zarówno w kręgach akademickich, jak i komercyjnych. To drobne, ale niezwykle urządzenie było przedmiotem wielu artykułów naukowych, głównie ze względu na jego wielofunkcyjność i możliwości wzmocnienia. W tym badaniu konwersja długości fali przy mieszaniu czterofalowym (FWM) została pomyślnie osiągnięta w SOA przy użyciu pojedynczego, ekonomicznego, niespójnego źródła z plasterkami widma, zarówno dla pompy, jak i sondy. Koncepcja ta ma znaczny potencjał do zastosowania w przyszłych opłacalnych systemach z pełnym pokrojeniem widma. (W pełni rozcięta widmo czterofalowa konwersja długości fali mieszania w półprzewodnikowym wzmacniaczu optycznym)*

Keywords: Semiconductor optical amplifier, four-wave mixing, spectrum-slicing

Słowa kluczowe: Półprzewodnikowy wzmacniacz optyczny, mieszanie czterofalowe, cięcie widma

Introduction

The semiconductor optical amplifier (SOA) continues to have many potential applications for future all-optical WDM transmission systems [1]. As well as gain, one of its many non-linear functions is wavelength (or frequency) conversion to avoid bottlenecks in our ever-increasing demands for speed and bandwidth [2]. Higher quality and cost-effective wavelength conversion is needed now more than ever, mainly due to the pressures put on it by the web in this modern, financially orientated age [3]. SOAs are the most promising candidates because of their special nonlinearity characters with a basic nonlinear photonic component [4].

Degenerate four-wave mixing (FWM) has been proposed as a method for achieving wavelength conversion in the context of wavelength division multiplexing (WDM) systems. This approach is favored for its notable efficiency in conversion and its rapid response speed [5]. Notably, efficient FWM is typically observed when both the pump and probe inputs share the same polarization.

While there has been extensive research on FWM using coherent light in various media [6-8], limited progress has been made in employing broadband light for this purpose. For instance, some work has explored FWM in nonlinear fibers [9] and utilized polarized amplified spontaneous emission (ASE) instead of a coherent laser as the probe source in semiconductor optical amplifiers (SOA) [10].

The growing demand for high-bandwidth access services is a significant driver for the advancement of cost-effective networks. Spectrum-slicing is a well-established technique involving the division of incoherent light using optical filters to produce extensive multi-wavelength light bundles [11]. Spectrum Slicing can be likened to transitioning from a single-lane road to a multi-lane highway without necessitating any alterations to existing end-user devices. Within Wi-Fi, Spectrum Slicing enables multiple radios to operate within the same 'band' and coverage area, though implementing this with more radios in the same coverage area requires intricate engineering.

Mobile Network Operators view Spectrum Slicing and Sharing as an efficient and feasible solution to meet the

growing data demands of present 5G networks and forthcoming 6G deployments. Successful spectrum sharing hinges on optimized spectrum partitioning, which entails dividing the spectrum for distribution among operators. This approach aims to enhance spectrum utilization, provide high-quality services, and augment revenues [12]. Typically, this technique employs a single, cost-effective multi-wavelength broadband source, like the amplified spontaneous emission (ASE) from an erbium-doped fiber amplifier (EDFA), with some additional filtering effects. Consequently, Spectrum-slicing presents an appealing and budget-friendly alternative with adaptable wavelength selection, as opposed to conventional WDM fiber optic communication systems that rely on multiple semiconductor lasers operating at distinct wavelengths for different data channels.

Performance-optimized WDM spectrum-sliced systems have potential applications in future local area network fiber communication systems for subscribers, demanding only economical equipment to improve data rates. However, a significant limitation of this technique is the notable inherent intensity noise, although this can be mitigated by leveraging the non-linear gain compression properties of saturated semiconductor optical amplifiers (SOA) [13]. In the future, local access networks employing spectrum-slicing may necessitate all-optical wavelength conversion for similar reasons as networks that utilize lasers [14].

In future local access networks adopting spectrum-slicing, there may be a need for all-optical wavelength conversion for similar reasons as networks utilizing lasers. Interestingly, to date there has only been one work published using total (both pump and probe) ASE for FWM in an SOA [15]. It is that actual practical work that we re-generate in this paper. Hence, our work reports on total spectrum-sliced four-wave mixing (FWM) wavelength conversion achieved in a single SOA using only a singular, and therefore low-cost, incoherent gaussian distributed optical white noise source. Section 2 introduces the technique used. Section 3 reviews the results obtained, section 4 discusses these and section 5 concludes the significance of the work.

Technique

The key features of spectrum slicing are considered as the provision of low-cost customer access as an alternative to laser systems [12]. The overall idea of a transmitter for SS-WDM is shown in Fig. 1 below. The filters are usually tuneable, eliminating the need for expensive tuneable lasers.

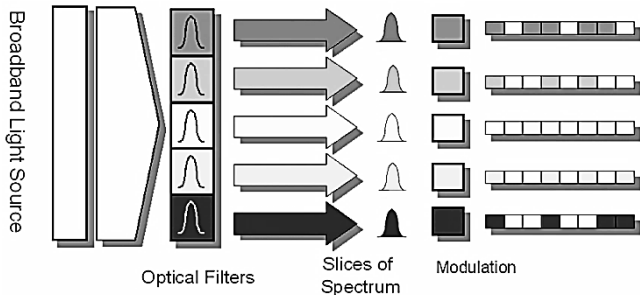

Fig. 1. The principles of spectrum-slicing [12]

Using state-of-the-art simulation software, the experimental system as shown in Fig. 1 was built. Both the pump and probe inputs required for FWM generation were firstly "spectrum-sliced" by very narrow band Bessel optical filters from a single white noise source, as shown in Fig. 2, and then multiplexed into the first SOA. This represents complete spectrum-sliced FWM wavelength conversion in an SOA. Only one wavelength conversion was chosen for this study, the pump and probe values set accordingly.

The conversion done was between pump frequency = 193.3 THz (1550.92 nm) and probe = 193.0 THz (1553.32 nm). Hence this represented a frequency up-conversion of 193.0 - 193.6 = 0.6 THz (or 600 GHz), or a down-

conversion of wavelength from 1553.33 to 1548.51 nm = 4.82 nm. The resulting FWM generated conjugate (before pre-amp) = 193.6 THz (approx. - 14 dBm), at 1548.51 nm. The probe input only was modulated using the software facility of a pseudo-random-bit-sequence (PRBS) of 10 gigabits/sec (10e09 bits/sec) with a non-return-to-zero (NRZ) format from a Mach-Zehnder (MZ) modulator. The FWM signal of interest was then amplified and filtered by another Bessel filter and then measured with the eye diagram analyser.

Polarization controllers were not attached, as was in work done in [15], since work done in [10] has subsequently shown successful polarization-independent and practical FWM wavelength converter that used a single, cost-effective ASE source filtered with a very narrow (7 pm) spectrally-sliced probe converter input. The total power into the functional SOA was set at pump power ~ 16 dBm. The probe power into this SOA was ~ 10 dBm. These inputs amounted to a very saturated SOA input [13] due to the EDFAs. The pump/probe ratio was chosen to be ~ 6 dB, similar to that in [4].

Results

The conversion efficiency, denoted as η , stands as a critical parameter in characterizing FWM signals. It quantifies as the ratio between the power of the FWM signal generated and the power of the input signal:

$$\eta = 10 \cdot \log \frac{P_{FWM}}{P_{signal}}$$

$$\eta = P_{FWM} - P_{signal} \text{ [dB]}$$

therefore η for our signal is approx.. [-14 - 10] = -24 dB (agreeing well with results in [4])

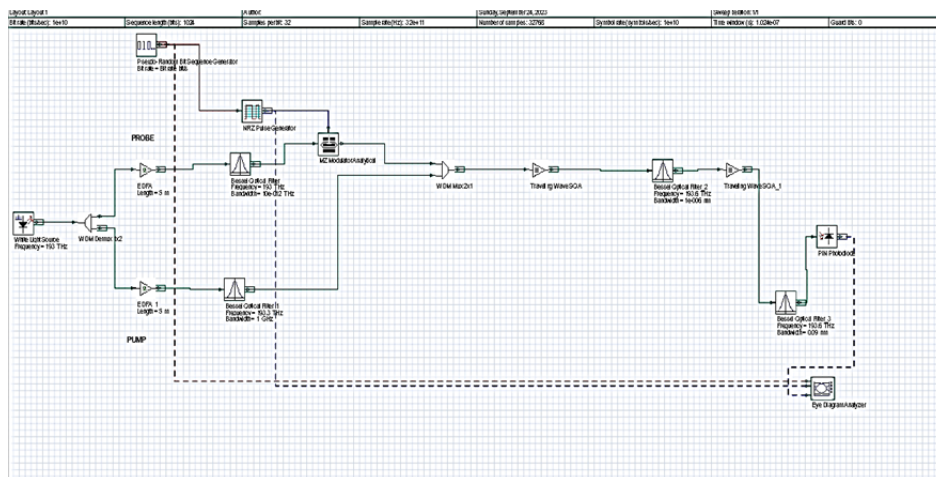

Fig. 2. Experimental set-up

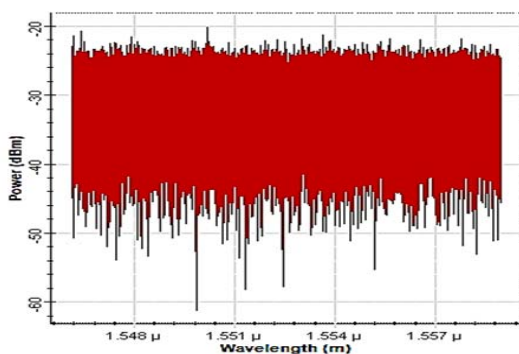

Fig. 3. White noise produced for spectrum slicing.

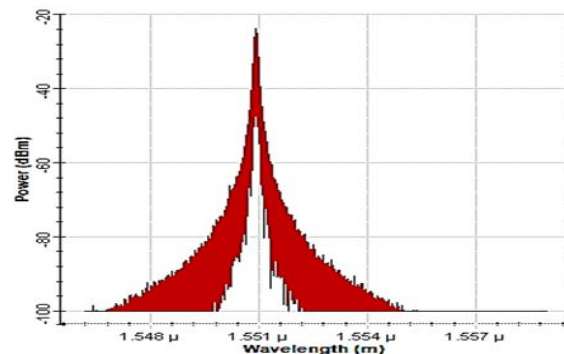

Fig. 4. Spectrum sliced pump 1550.92 nm from Bessel filter.

Fig. 3 shows the white noise spectrum produced from the source, which was then spectrum-sliced by the filters to form the probe and pump arms using a 1x2 demultiplexer. Both signals were amplified by EDFAs before entry into the first SOA, thus ensuring good gain saturation [13].

Figs 4 and 5 show the spectrum sliced pump and probes, respectively, from the Bessel filters. Fig. 6 shows the waveforms multiplexed into the first SOA, and Fig. 7 the probe input eye diagram.

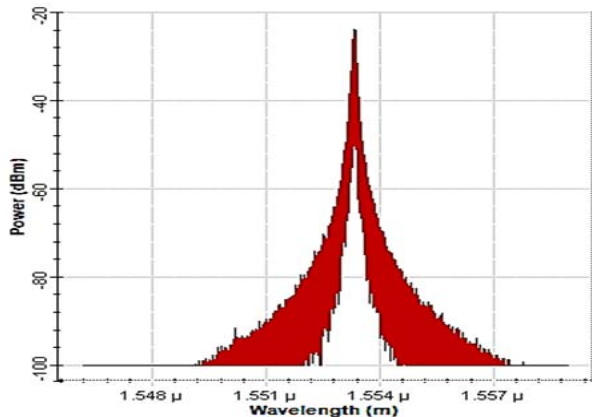

Fig.5. Spectrum sliced probe 1553.33 nm from Bessel filter.

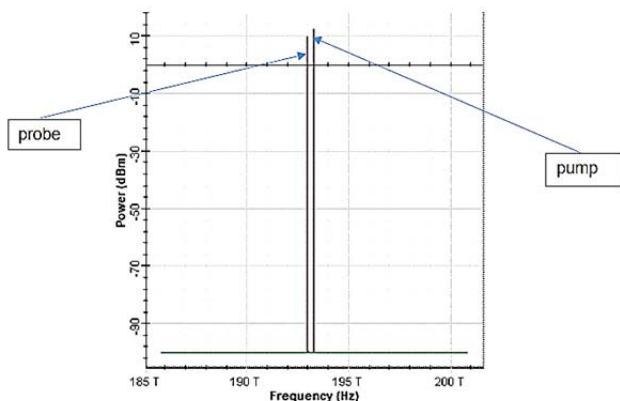

Fig.6. Spectrum-sliced pump and probes multiplexed into SOA input.

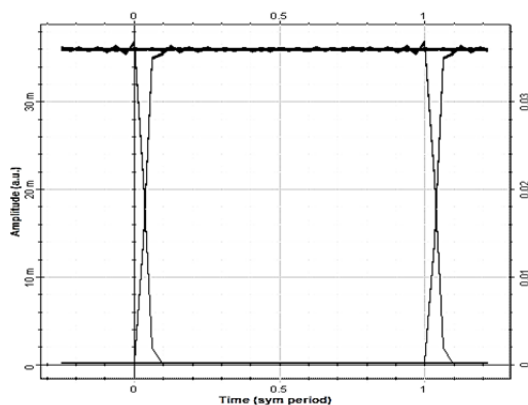

Fig.7. Eye into SOA from modulator (Q factor ~ 14)

Fig. 8 shows the FWM spectra achieved from the SOA output, the extra sidebands generated were considered too small to be of use. Figs 9 and 10 show the filtered and amplified FWM signal output conjugate obtained in both spectra and eye format, respectively.

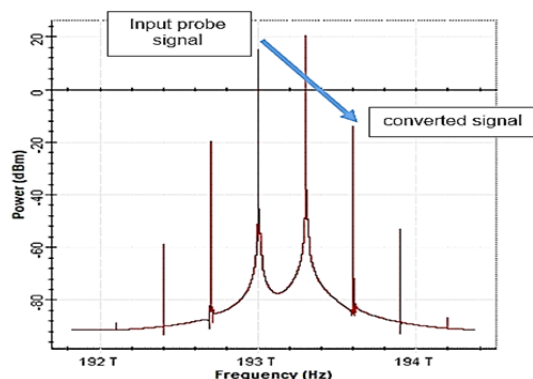

Fig.8. Output wavelengths produced from SOA (blue arrow showing the up-converted frequency of interest)

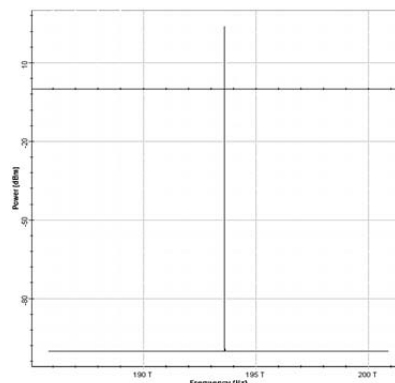

Fig.9. Filtered and amplified FWM converted signal.

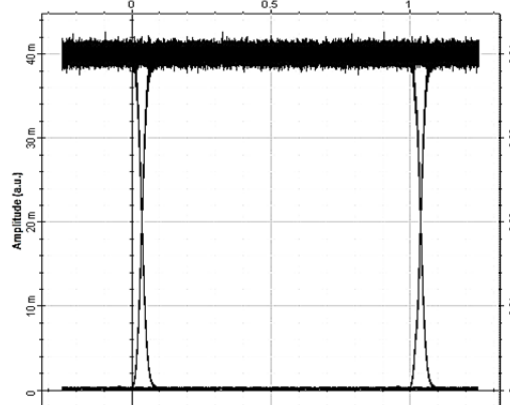

Fig. 10. Converted FWM eye out (Q factor ~ 6)

Discussion

On the whole, the results show that the technique works quite well. An effective converted eye output with a Q-factor of 6 has been achieved from a pure white noise source. Obviously when dealing with highly incoherent light such as here, very fine filtering and adequate amplification is required to meet the standard for a real spectrum-slicing system. The software freely allows for experimentation by trial and error in order to fully optimize the system - unlike real measurement which would involve many very expensive changes in filtering equipment etc. Of course, there are limitations in the software – just as there are limitations in any practical equipment and instruments. One would therefore infer that this experiment can now be run practically to check for similarities with results achieved here.

Conclusions

This theoretical treatise produced in this work backs up the practical achievements made in [15] by obtaining similar results, hence proving that the technique is viable.

Unfortunately, at the time, the results achieved in that innovative and novel work were never improved upon. Yet, the whole scheme has been shown to be highly cost effective, with just a single incoherent source used for the pump and probe, and a single SOA for the conversion. This technique still has huge potential for application in future, local access, completely spectrum-sliced networks where wavelength conversion will be required.

Acknowledgements

Special thanks to the Photonics Engineering (PERG) research group at UTeM, Melaka, Malaysia for the use of their simulation software.

Corresponding author: David Forsyth, Department of Electronics and Computer Engineering Technology (JTKEK), Universiti Teknikal Malaysia Melaka (UTeM), Jalan Hang Tuah Jaya, 76100 Durian Tunggal, Melaka, Malaysia; david@utem.edu.my.

REFERENCES

- [1] D. Forsyth and F. D. Mahad, Semiconductor Optical Amplifiers: Present and Future Applications, chapter 5 in book Optical Communication & Networking (Volume II), published by UTM press (2016)
- [2] E. Sillekens, F. M. Ferreira, R. I. Killey and P. Bayvel, Experimental Demonstration of a Simplified SOA Nonlinearity Mitigation scheme, presented at Optical Fibre Communications Conference and Exhibition (OFC), DOI: 10.1364/OFC.2023.W3E.5 (2023)
- [3] P. Zhao *et al*, 100-Gbps per-channel all-optical wavelength conversion without pre-amplifiers based on an integrated nanophotonic platform, Nanophotonics journal, vol. 12, no. 17, pp. 3427-3434 (2023)
- [4] T. Akylbek, T. Akhmet and T. Liliya, Experimental study of four-wave mixing based on a quantum dot semiconductor optical amplifier, International Journal of Electrical and Computer Engineering (IJECE), vol.13, no. 5, pp. 5179 - 5189 (2023)
- [5] W. Ge, Measurements of the dispersion, the dispersion slope and nonlinear coefficients of photonic crystal fibres based on degenerate four-wave mixing (FWM), Journal of Optical Communications, published by De Gruyter, vol. 44, no. 2, pp. 179-183 (2023)
- [6] S. Montazeri and M. Esmaelpour, Entangled photon pair generation via spontaneous intermodal four-wave mixing in a 25-km-long few-mode fibre, Proc. SPIE 12446, Quantum Computing, Communication, and Simulation III, doi: 10.1117/12.2650661 (2023)
- [7] N. A. Cholan *et al*, Multi-wavelength generation by self-seeded four-wave mixing, Optics Express, 21 (5). pp. 6131-6138. ISSN 1094-4087 (2013)
- [8] N. Dessmann *et al*, Highly efficient THz four-wave mixing in doped silicon, Light: Science & Applications journal, vol. 10, nos. 71 (2021)
- [9] O. M. Kharraz, H. Ahmad, D. I. Forsyth *et al*, All-incoherent wavelength conversion in highly nonlinear fibre using four-wave mixing, Opt. Eng., vol. 53, issue 9, doi:10.1117/1.OE.53.9.096112 (2014)
- [10] O. M. Kharraz, A. B. Mohammad, D. I. Forsyth, A. A. Jasim and H. Ahmad, Polarization-independent ASE four-wave mixing in a fast semiconductor optical amplifier, Optics Communications journal, vol. 355, pp 498–503 (2015)
- [11] M. Srinivasan, C. S. R. Murthy *et al*, Efficient Spectrum Slicing in 5G Networks: An Overlapping Coalition Formation Approach, IEEE Transactions on Mobile Computing, vol. 19, Issue: 6, pp. 1299 - 1316 (2020)
- [12] M. S. Leeson and S. Sun, Spectrum Slicing for Low Cost Wavelength Division Multiplexing, published in 2nd ICTON Mediterranean Winter Conference, DOI: 10.1109/ICTONMW.2008.4773127 (2008)
- [13] R. A. Johni, D. I. Forsyth and K. R. Tariq, Effects on semiconductor optical amplifier gain quality for applications in advanced all-optical communication systems, Research Journal of Applied Science, Engineering and Technology (RJASET), vol. 7, issue 16, pp. 3414-3418 (2014)
- [14] O. M. Kharraz, H. Ahmad, A. B. Mohammad, D. I. Forsyth, M. Dernayka and S. Harun, Performance enhancement of pre-spectrum slicing technique for wavelength conversion, Optics Communications journal, vol. 350, pp 154–159 (2015)
- [15] D. I. Forsyth and M. J. Connelly, Spectrum-sliced wavelength conversion using Four-wave mixing from a semiconductor optical amplifier, presented at Optical Amplifiers and their Applications (OAA) Conference, Budapest, Hungary, Aug. 7 – 10, (2005)